

VELIA EM

THE QUICK AND EASY NEXT-LEVEL ORDER PICKER

In order picking, where the pressure is on, trucks are put to the test and only the strongest survive. Our VELiA EM range of second-level order pickers is truly exceptional. Developed for efficient and safe picking, this 1000 kg workhorse does more than protect your operators... it works harmoniously with them, too.



OPBL10P
with EasyLift

OPBL10P
without EasyLift

PRELIMINARY
SPEC SHEET

Second Level Order Pickers

1.0 tonnes



Take its ultra-low step height. At just 160mm, it's up to 45% lower than some competitors. But, more than that, it significantly reduces your operator's efforts, as well as the risk of slips, trips and falls.

And then there's VELiA EM's wide entry. At 603 mm wide, it can accommodate drivers of all sizes in comfort.

FRAME AND BODY

- **MaxVision** (option not standard) mast and overhead guard maximises operator field of vision for increased productivity and safety.
- **Robust design** ensures smooth, stable ride and excellent picking performance.
- **Wraparound steel bumper** increases durability and operator protection.

DRIVE

- **Powerful AC motor** means high drive speed and acceleration – even when loaded – plus smooth, quiet, controlled operation, extended shift length and lower maintenance requirements.
- **ECO mode** reduces energy consumption – without compromising on performance.
- **High-speed option increases speed from 9 to 12 km/hr.**

VELiA EM

Mitsubishi OPBL10P Series

Second Level Order Pickers

1.0 tonnes

ELECTRICAL CONTROL SYSTEMS

- **Performance setting** – including pre-set modes – allows instant programming without special tools.
- **On-board diagnostics and fault memory folder** keep operator and service engineer aware of any problems, speed up servicing and help prevent damage.

OPERATOR ENVIRONMENT & CONTROLS

- **Class-leading step height (just 160mm)** offers easy on/off access to keep operators alert and productive throughout shifts.
- **Easy-access operator's compartment** is spacious and features widest entry in its class for faster mounting and dismounting.
- **EasyLift design** (standard with 1800mm model and optional with 1200mm model) allows operators to raise/lower the pallet to comfortable heights during picking and retrieving, reducing the risk of back strain.
- **High-visibility cabin** maximises forward views for reduced damage risk, while increasing operator comfort and efficiency.
- **Operator Presence Sensor** covers a wide area – allowing for free operator movement, while eliminating a common trip hazard.
- **Super-grip floor** is non-slip ensuring operators are safe, for confident operations.

- **PIN-code access** for up to 100 users is possible – preventing unauthorised use.
- **Battery discharge indicator** keeps operators aware of battery discharge levels – ensuring high-efficiency operations and long battery life.
- **MaxPro side-access gates with automatic sensors** (standard with EasyLift design and optional with 1200mm lift without EasyLift design) prevent unsafe use of truck with gates open at heights above 1200 mm.
- **Easy-access storage compartments** ensure pickers have everything they need to work productively within easy reach.
- **Ergonomic steering wheel** offers smooth controlled movement to keep operators alert and operations precise.

OTHER FEATURES

- **Rapid battery access** reduces time needed for daily checks and maintenance – for maximum uptime.
- **Robust battery rollers** speed up changeovers – ensuring pickers can focus on their job.



There is more information on VELiA EM on mitforklift.com

For more extensive information on this range please visit our website mitforklift.com



Continuing improvement may lead to changes in these specifications

mft2.eu/veliaem

| Characteristics | | | | without EasyLift | with EasyLift |
|----------------------------|--|-------|-------|---|---------------------------|
| 1.1 | Manufacturer | | | Mitsubishi | Mitsubishi |
| 1.2 | Manufacturer's model designation | | | OPBL10P | OPBL10P |
| 1.3 | Power source: (battery, diesel, LP gas, petrol) | | | Battery | Battery |
| 1.4 | Operator type: pedestrian, (operator)-standing, -seated | | | Stand-on | Stand-on |
| 1.5 | Load capacity ¹⁾ | Q | kg | 1000 | 1000 |
| 1.6 | Load center distance | c | mm | 600 | 600 |
| 1.8 | Load wheel axle to fork face (forks lowered) | x | mm | 100 | 120 |
| 1.9 | Wheelbase | y | mm | 1371 | 1371 |
| Weight | | | | | |
| 2.1a | Truck weight with load, with minimum battery weight | | kg | 2450 | 2600 |
| 2.2a | Axle loadings with nominal load & minimum battery weight, drive/load side | | kg | 430 / 2020 | 440 / 2160 |
| 2.3a | Axle loadings without load & with minimum battery weight, drive/load side | | kg | 950 / 500 | 950 / 650 |
| Wheels, Drive Train | | | | | |
| 3.1 | Tyres: PT=Power Thane, Vul=Vulkollan, drive/load side | | | Vul / Vul | Vul / Vul |
| 3.2 | Tyre dimensions, drive side | | mm | 250 × 105 | 250 × 105 |
| 3.3 | Tyre dimensions, load side | | mm | 120 × 115 | 120 × 115 |
| 3.5 | Number of wheels, load/drive side (x=driven) | | | 2 / 1x | 2 / 1x |
| 3.7 | Track width (center of tyres), load side | b11 | mm | 674 | 674 |
| Dimensions | | | | | |
| 4.2 | Height with mast lowered | h1 | mm | 1630 | 2196 |
| 4.4 | Lift height (without h9) | h3 | mm | 1040 | 1640 |
| 4.5 | Height with mast extended | h4 | mm | 2670 | 3790 |
| 4.7 | Height to top of overhead guard | h6 | mm | 2300 | 2300 |
| 4.8 | Seat- or stand height | h7 | mm | 160-1200 | 160-1800 |
| 4.10 | Height of support legs | h8 | mm | 115 | 115 |
| 4.11 | Supplementary lift | h9 | mm | 723 | 723 |
| 4.14 | Platform height, raised | h12 | mm | 1200 | 1800 |
| 4.15 | Fork height, fully lowered | h13 | mm | 90 | 90 |
| 4.19 | Overall length | l1 | mm | 2805 | 2825 |
| 4.20 | Length to fork face | l2 | mm | 1655 | 1675 |
| 4.21 | Overall width | b1 | mm | 810 | 810 |
| 4.22 | Fork dimensions (thickness, width, length) | s/e/l | mm | 70 / 147 / 1150 | 70 / 147 / 1150 |
| 4.25 | Outside width over forks (minimum/maximum) | | mm | 450-700 | 450-700 |
| 4.32 | Ground clearance at center of wheelbase (forks lowered) | m2 | mm | 35 | 35 |
| 4.33a | Aisle width for pallets 1000 × 1200 (l6 × b12) crossways | Ast | mm | Platform/load width + 90 mm clearance each side | |
| 4.34a | Aisle width for pallets 800 × 1200 (b12 × l6) lengthways | Ast | mm | 3131 | 3150 |
| 4.35 | Turning radius | Wa | mm | 1570 | 1570 |
| 4.41 | Transfer aisle width (pallet 1000 × 1200mm lengthwise & 200 mm clearance) | | mm | Platform/load width + 90 mm clearance each side | |
| Performance | | | | | |
| 5.1 | Travel speed, with / without load | | km/h | 9 / 9 | 9 / 9 |
| 5.2 | Lifting speed, with / without load | | m/s | 0.12 / 0.20 | 0.11 / 0.19 |
| 5.3 | Lowering speed, with / without load | | m/s | 0.25 / 0.23 | 0.24 / 0.22 |
| 5.8 | Max gradeability, with / without load | | % | 10.2 | 10.2 |
| 5.9 | Acceleration time (over 10 m), with / without load | | s | 5.6 / 4.9 | 5.5 / 4.8 |
| 5.10 | Service brake | | | Regenerative / electrical | Regenerative / electrical |
| Electric motors | | | | | |
| 6.1 | Drive motor capacity (60 min. short duty) | | kW | Mahle 2,7 | Mahle 2,7 |
| 6.2 | Lift motor output at 15% duty factor | | kW | 2,2 (5%) | 2,2 (5%) |
| 6.3 | Battery according to DIN 43531/35/36, A, B, C, no | | | BS | BS |
| 6.4 | Battery voltage / rated capacity (5 h) | | V/Ah | 24 / 486-600 | 24 / 486-600 |
| 6.5 | Battery weight (± 5%) | | kg | Min 450 | Min 450 |
| 6.6 | Energy consumption according to VDI cycle | | kWh/h | n/a | n/a |
| Miscellaneous | | | | | |
| 8.1 | Type of drive control | | | AC Traction | AC Traction |
| 8.4b | Level of noise at the ear level of the driver according to EN 12 053:2001 and EN ISO 4871 in work LpAZ | | db(A) | 57 | 57 |

¹⁾ If adjustable forks, then load capacity is max 900 kg on LC 600 mm

Continuing improvement may lead to changes in these specifications

VELIA EM

Mitsubishi OPBL10P Series

Second Level Order Pickers

1.0 tonnes

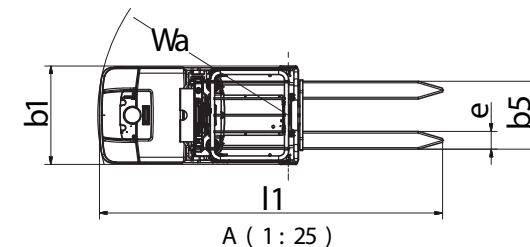
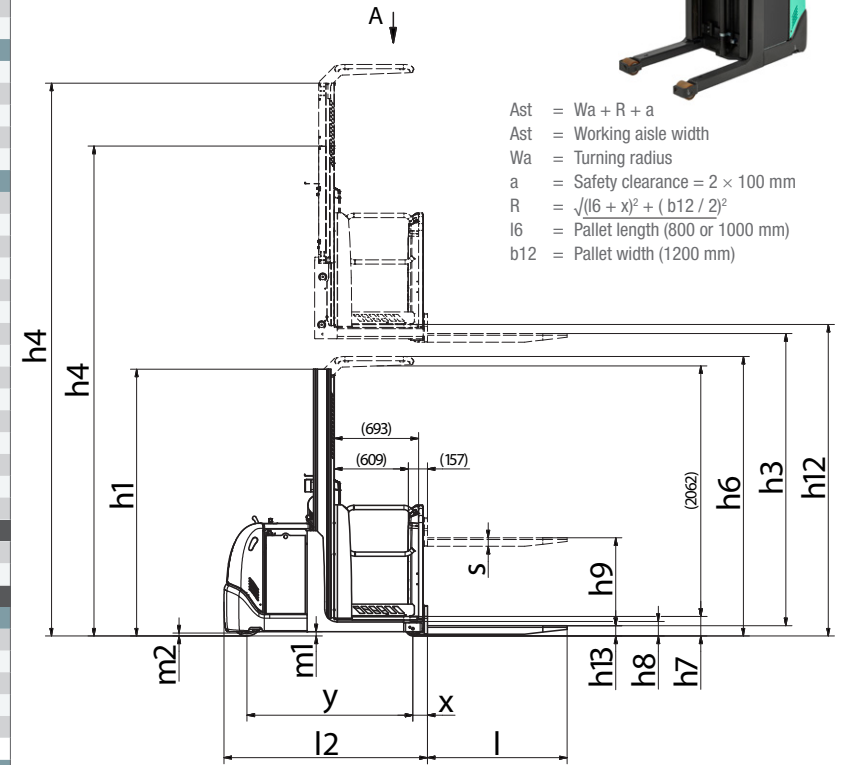

| LOAD DERATION – Q KG OPBL10P Load deration based on load evenly spread along the forks | | | | | | | |
|--|--------------------|----------------------|------------------------------------|----------------------|-------------------------|--|------------------|
| h4 mm | h3 mm | h5 mm | h mm | D mm | No EasyLift Fixed forks | With EasyLift (Stroke EasyLift 720 mm) | |
| | | | | | | Fixed forks | Adjustable forks |
| Platform floor height | Closed mast height | Mast height extended | Fork height | Load center distance | Max capacity | Max capacity | Max capacity |
| 1200 | 1630 (pillars) | 2670 | H4 - 70 = 1130 No EasyLift | 400-600 | 1000 | - | - |
| | | | H4 - 70 + 720 = 1850 With EasyLift | 400-600 | - | 1000 | n/a |
| | | | | 400-500 | - | 1000 | 1000 |
| | | | | 80 | - | 1000 | 900 |

| LOAD DERATION – Q KG OPBL10P WITH EASYLIFT (Stroke EasyLift 720 mm) Load deration based on load evenly spread along the forks | | | | | | |
|---|--------------------|----------------------|----------------------|----------------------|--------------|------------------|
| h4 mm | h3 mm | h5 mm | h mm | D mm | Fixed forks | Adjustable forks |
| | | | | | Q kg | Q kg |
| Platform floor height | Closed mast height | Mast height extended | Fork height | Load center distance | Max capacity | Max capacity |
| 1800 | 2196 | 3790 (pillars) | H4 - 70 + 720 = 2450 | 400-600 | 1000 | - |
| | | | | 400-500 | 1000 | 1000 |
| | | | | 600 | 1000 | 900 |



Continuing improvement may lead to changes in these specifications

VELIA EM

Mitsubishi OPBL10P Series

Second Level Order Pickers

1.0 tonnes

| | OPBL10P without EasyLift | OPBL10P with EasyLift |
|---|-----------------------------|--------------------------|
| GENERAL | | |
| Micro-computer incl. Hour meter and battery indicator | ● | ● |
| PIN code log in, 100 codes | ● | ● |
| Key switch entry | ● | ● |
| Drive and lift controls on mast side | ● | ● |
| Operators presence sensor in floor | ● | ● |
| Cornering control | ● | ● |
| MaxPro gates | ● | ● |
| Warning light | ● | ● |
| Battery on steel rollers | ● | ● |
| ENVIRONMENT | | |
| Chill store design, with rust protected axles | ● | ● |
| Cold store modification (-35°C) | ● | ● |
| DRIVE, LIFT CONTROLS | | |
| EasyLift | ● | ● |
| Extra buttons for EasyLift (mast side) | ● | ● |
| Walk beside, drive buttons and EasyLift buttons | ● | ● |
| COMPUTER EQUIPMENT | | |
| Operator and vehicle management | ● | ● |
| SAFETY | | |
| MaxPro side access gates | ● | ● |
| MaxVision overhead guard | ● | ● |
| Gate interlock, <1200 mm platform height | ● | ● |
| Gate open audible warning, >415 mm platform lift | ● | ● |
| OTHER | | |
| Increased drive speed, 12 km/h | ● | ● |
| Easyview display with steering wheel indicator | ● | ● |
| Mini steering wheel | ● | ● |
| Key switch entry | ● | ● |
| Light in cabin (racks) | ● | ● |
| Light in cabin (interior) | ● | ● |
| Radio with MP3 | ● | ● |
| Converter 24-12 V, 8 A, 96 W outlet | ● | ● |
| 12 V / 8 A DC power socket | ● | ● |
| Equipment holder, RAM system, Size C | ● | ● |
| Foldable driver's cushion | ● | ● |
| Converter 24-12 V, 8 A, 96 W outlet | ● | ● |
| Comfort fan for driver | ● | ● |
| Extra storage in platform | ● | ● |
| Fire extinguisher | ● | ● |

● Standard ● Option

Continuing improvement may lead to changes in these specifications



EasyLift control



Optional driver's cushion



Walk-beside control



Robust battery rollers



VELIA

THE FRONT RUNNER

When developing the award-winning VELiA family of low, mid and high level order pickers, our primary aim was to deliver exceptional productivity through unrivalled ergonomics and driveability.

when **reliability** is **everything...**

Like any product bearing the Mitsubishi name, our materials handling equipment benefits from the tremendous heritage, huge resources and cutting-edge technology of one of the world's largest corporations – Mitsubishi Heavy Industries Group.

Engineering spacecraft, jet planes, power plants and more, MHI specialises in those technologies where performance, dependability and superiority decide your success or failure...

So when we promise you **quality, reliability** and **value for money**, you know it's a guarantee we have the power to deliver.

That's why every model in our award-winning and comprehensive range of lift trucks and warehouse equipment is built to a high specification – to ensure it keeps working for you. Day after day. Year after year. Whatever the job. Whatever the conditions.

YOU'LL NEVER WORK ALONE

As your local authorised dealer, we are here to keep your trucks working – through our extensive experience, our technical excellence and our commitment to customer care.



We are your local experts, backed by efficient channels to the entire Mitsubishi Forklift Trucks organisation.

No matter where you are, we are close by – with the capability to meet your needs.

Discover how Mitsubishi gives you more from your local authorised dealer or when you visit our website www.mitforklift.com

Performance specifications may vary depending on standard manufacturing tolerances, vehicle condition, types of tyres, floor or surface conditions, applications or operating environment. Trucks may be shown with non-standard options. Specific performance requirements and locally available configurations should be discussed with your distributor of Mitsubishi forklift trucks. Mitsubishi follows a policy of continual product improvement. For this reason, some materials, options and specifications could change without notice.

mitforklift@mcfe.nl www.mitforklift.com

WESM1921P (08/18) © 2018 MCFE

