

AXiA EM

PLATFORM STACKERS

1.2 - 1.6 tonnes

**MINIMISE YOUR EFFORT...
MAXIMISE YOUR VERSATILITY**

Designed to 'do it all', our AXiA EM 1.2 and 1.6 tonne platform stackers are the perfect choice for medium stack applications in narrow spaces. However, they excel when shuttling and picking, too. By specifying the Initial Lift option, you can even use it as a double pallet handler, too.

SPECIFICATIONS

SBV12P
SBV12P(I)
SBV16P
SBV16P(I)
SBV16P(S)



**WHEN
RELIABILITY IS
EVERYTHING...**

AXiA EM

SBV12P(I) -16P(I)(S) Series

PLATFORM STACKERS

1.2 – 1.6 tonnes



Offering a drive speed of 8.5 km/h, this truck's performance is among the best in its class. It's low maintenance, too, thanks to its easy accessibility and protection against dust and water.

Its robust folding platform is cast in iron - ensuring it can resist knocks, while offering exceptional cushioning. For easy, safe on/off access, side guards can be quickly and easily folded out or in.

For safe and comfortable working above a lift height of 1.8 m, AXiA EM can be fitted with a fixed overhead guard. Additionally a stationary operator platform is available.

DRIVE

- **Initial Lift** increases versatility by allowing the truck to operate on uneven floors and serve as a double pallet handler. (Optional)
- **Powerful AC drive motor** means high drive speed (up to 8.5 km/h) and acceleration - even when loaded - plus smooth, quiet, controlled operation, extended shift length and lower maintenance requirements.

MAST

- **Wide range of lift heights and mast types** includes triplex masts and a choice of standard or free lift masts.

OPERATOR ENVIRONMENT AND CONTROLS

- **Easy-to-operate tiller arm** features large, easy-use buttons so operators can focus on the task in hand.
- **Ultra-low step height** offers easy on/off access to keep operators alert and productive through shifts.



- **Left-handed or right-handed controls** are possible, thanks to the versatile tiller arm.
- **Easy, foldable side bars (option)** eliminates the need for operators to step off the platform for highly efficient, safe operations.
- **Dampened platform** encourages a natural operating stance for additional protection of operators against knocks or bumps.
- **Keypad and display on tiller head** Easy to activate the truck, change settings and get information

FRAME AND BODY

- **Robust cast-iron platform** offers outstanding cushioning for shift-after-shift comfort.

ELECTRICAL AND CONTROL SYSTEMS

- **Electronic power steering** means smooth, precise control with minimal effort and maximum comfort. (Optional)
- **Power steering resistance** offers a natural driving experience - keeping drivers alert and working safely.
- **Battery discharge indicator** prevents deep discharge and allows for use to be monitored.
- **PIN-code access** prevents unauthorised use of the truck.
- **Performance setting** including pre-set modes - allows instant programming without special tools.
- **Battery rollers** make changes quick, easy and safe.

- **Li-ion battery (optional)** allows for fast charging - removing the need for extra batteries.

FORKS

- **Tapered forks** enhance safety, while offering quicker and easier access to pallets in racks or block stacks.

OTHER

- **Rapid access features** give quick and easy entry to all areas for checks and servicing.



There is more information on AXiA on mitforklift.com

For more extensive information please visit our website mitforklift.com



mft2.eu/axiaem

VDI - PERFORMANCE & DIMENSIONS

AXIA EM

PLATFORM STACKERS

SBV12P(I) - 16P(I)(S)

1.2- 1.6 tonnes

CHARACTERISTICS			Mitsubishi Forklift Trucks	Mitsubishi Forklift Trucks	Mitsubishi Forklift Trucks	Mitsubishi Forklift Trucks	Mitsubishi Forklift Trucks
1.1	Manufacturer		Mitsubishi Forklift Trucks	Mitsubishi Forklift Trucks	Mitsubishi Forklift Trucks	Mitsubishi Forklift Trucks	Mitsubishi Forklift Trucks
1.2	Manufacturer's model designation		SBV12P	SBV12P(I)	SBV16P	SBV16P(I)	SBV16P(S)
1.3	Power source		Battery	Battery	Battery	Battery	Battery
1.4	Operator type		Pedestrian / Stand-on	Pedestrian / Stand-on	Pedestrian / Stand-on	Pedestrian / Stand-on	Pedestrian / Stand-on
1.5	Load capacity	Q kg	1250	1250	1600	1600	1600
1.6	Load center distance	x mm	600	600	600	600	600
1.8	Load wheel axle to fork face (forks lowered)	c mm	750	750	800	800	800
1.9	Wheelbase	y mm	1412	1646	1529	1501	1565
WEIGHT							
2.1	Truck weight without load, with maximum battery weight	kg	1317 h13 + h3 = 4200	1317 h13 + h3 = 4200	1230	h13 + h3 = 3600	h13 + h3 = 3600
2.2	Axle loadings with nominal load & maximum battery weight, drive / load side	kg	1130/1457	1130/1457	738 / 1085	738 / 1085	930 / 2030
2.3	Axle loadings without load & with maximum battery weight, drive / load side	kg	924/403	924/403	930 / 350	930 / 350	940 / 420
WHEELS, DRIVE TRAIN							
3.1	Tyres: PT = Power Thane, Vul = Vulkollan, P = Polyurethane, N = Nylon, R = Rubber drive / load side		PT	PT	Vul / Vul	Vul / Vul	Vul / Vul
3.2	Tyre dimensions, drive side	mm	ø230 × 70	ø230 × 70	ø230 × 90	ø230 × 90	ø230 × 90
3.3	Tyre dimensions, load side	mm	ø85 × 99	ø85 × 99	ø85 × 70	ø85 × 70	ø85 × 70
3.4	Castor wheel dimensions (diameter x width)	mm	ø140 × 60	ø140 × 60	ø140 × 60	ø140 × 60	ø140 × 60
3.5	Number of wheels, load / drive side (x = driven)		1x + 1/2	1x + 1/2	1x+1/4	1x+1/4	2+1x/4
3.6	Track width (center of tyres), drive side	b10 mm	501	501	501	501	550
3.7	Track width (center of tyres), load side	b11 mm	380	380	390	980 / 1180	980 / 1180
DIMENSIONS							
4.2b	Height	h1 mm	see tables	see tables	see tables	see tables	see tables
4.3	Free lift	h2 mm	see tables	see tables	see tables	see tables	see tables
4.4	Lift height	h3 mm	see tables	see tables	see tables	see tables	see tables
4.5	Height with mast extended	h4 mm	see tables	see tables	see tables	see tables	see tables
4.6	Initial lift	h5 mm	-	110	-	110	-
4.7	Height to top of overhead guard	h6 mm	2288	2288			
4.8	Seat- or stand height	h7 mm	165	165	165	165	145
4.9	Height of tiller arm / steering console (min./max.)	h14 mm	1090/1470	1090/1470	1090 / 1470	1090 / 1470	1141/1341
4.10	Height of support legs	h8 mm	82	82	80	80	-
4.15	Fork height, fully lowered	h13 mm	90	90	85	85	75
4.19	Overall length	l1 mm	2107	2216 / 2622	2140 / 2524 (l=1150)	2185 / 2569 (l=1150)	2175 / 2559 (l=1150)
4.20	Length to fork face	l2 mm	907	1016 / 1422	990 / 1374	1035 / 1419	887 / 1343
4.21	Overall width	b1/b2 mm	770	770	770	770	1105 / 1305
4.22	Fork dimensions (thickness, width, length)	s/e/l mm	65 / 180 / 1200, 1000	65 / 180 / 1200, 1000	65 / 180 / 1150, 1000	65 / 180 / 1200, 1000	40 / 100 / 1150, 1000, 800
4.24	Fork carriage width	b3 mm	590	590	730	730	840
4.25	Outside width over forks (minimum / maximum)	b5 mm	570	570	570	570	216 / 773
4.26	Inner width of support legs	b4 mm	210	210	265	235	855 / 1055
4.32	Ground clearance at center of wheelbase, (forks lowered)	m2 mm	28	28	25	25	38
4.33c	Working aisle width (Ast) with 1000 x 1200 mm pallets, load crosswise, platform up/down	Ast mm	2526 / 2909	2515 / 2935	2535 / 2920(l=1000)	2604 / 2979 (l=1000)	2547 / 2931(l=1000)
4.34c	Working aisle width (Ast) with 800 x 1200 mm pallets, load lengthwise, platform up/down	Ast mm	2479 / 2862	2537 / 2957	2557 / 2942 (l=1150)	2538 / 2913 (l=1150)	2593 / 2977 (l=1150)
4.34d	Working aisle width (Ast3) with 800 x 1200 mm pallets, load lengthwise, platform up/down	Ast3 mm	2325 / 2708	2515 / 2935	2390 / 2775	2372 / 2747	2579 / 2963
4.35	Turning radius	Wa mm	1675 / 2058	1865 / 2285	1790 / 2175	1172 / 2147	1826 / 2210
PERFORMANCE							
5.1	Travel speed, with / without load	km/h	5.6 / 5.6	5.6 / 5.6	8.5 / 8.5	8.5 / 8.5	9/9
5.2	Lifting speed, with / without load	m/s	0.13 / 0.26	0.13 / 0.26	0.16 / 0.33	0.16 / 0.33	0.13 / 0.23
5.3	Lowering speed, with / without load	m/s	0.33 / 0.21	0.33 / 0.21	0.39 / 0.31	0.39 / 0.31	0.20 / 0.12
5.7	Gradeability, with / without load	%	7 / 9	7 / 9			
5.8	Maximum gradeability with / without load	%	7 / 9	9.9 / 21.4	7	14.6 / 26.5	10 / 10
5.9	Acceleration time (10 metres) with / without load	s	7.9 / 7.5	7.9 / 7.5	6.6 / 5.6	6.6 / 5.6	6.6 / 5.6
5.10	Service brakes (mechanical / hydraulic / electric / pneumatic)		Electric	Electric	Electric	Electric	Electric
ELECTRIC MOTORS							
6.1	Drive motor capacity (60 min. short duty)	kW	1.3	1.3	2.2	2.2	2
6.2	Lift motor output at 15% duty factor	kW	1	1	3.6	3.6	3
6.4	Battery voltage/capacity at 5-hour discharge	V/Ah	24V / 220Ah-400Ah	24V / 220Ah-400Ah	24V / 220Ah-400Ah	24V / 220Ah-400Ah	224V / 375Ah
6.5	Battery weight	kg	250-370	250-370	250-370	250-370	285
6.6b	Energy consumption according to EN16796	kWh/h			1.138	1.138	1.138
MISCELLANEOUS							
8.1	Type of drive control		Stepless	Stepless	Stepless	Stepless	Stepless
10.7	Level of noise at the ear level of the driver according to EN 12 053:2001 and EN ISO 4871 in work LpAZ	dB(A)	62.8	62.8			
10.7.1	Level of noise at the ear level of the driver according to EN 12 053:2001 and EN ISO 4871, drive/lift/idle LpAZ	dB(A)			67,5	67,5	67,5

MAST PERFORMANCE AND CAPACITY

AXIA EM

SBV12P(I)-16P(I)(S) Series PLATFORM STACKERS

1.2 – 1.6 tonnes

DS = Duplex with clear-view mast
 DEV = Duplex with full free lift
 TREV = Triplex with full free lift
 h3+h13 = Lifting height
 h1 = Lowered mast height
 h2+h13 = Free lift

Ast = Working aisle width
 Ast3 = Working aisle width (b12 < 1000 mm)
 $Ast = Wa + \sqrt{(l6 - x)^2 + (b12/2)^2} + a$
 Ast3 = $Wa + l6 - x + a$

Wa = Turning radius
 l6 = Pallet length
 x = Load wheel axle to fork face
 b12 = Pallet width
 a = Safety clearance = 2 x 100 mm

SBV12 - 16P(I)

MAST TYPE	h3 + h13 mm	h1* mm	h2 + h13 mm
SBV12P(I)			
DUPLEX (DS)	2690	1845	80
	2990	1995	80
	3290	2150	80
	3590	2300	80
	4190	2600	80
DUPLEX FREE-LIFT (DEV)	2690	1845	1433
	2990	1995	1583
	3290	2150	1738
	3590	2300	1888
	4190	2600	2188

MAST TYPE	h3 + h13 mm	h1* mm	h2 + h13 mm
SBV16P(I)(S)			
DUPLEX (DS)	1670	1390	130
	2400	1755	130
	2900	2005	130
	3200	2155	130
	3600	2355	130
	3800	2455	130
DUPLEX FREE-LIFT (DEV)	1670	1385	835
	2400	1750	1200
	2900	2000	1450
	3200	2150	1600
	3600	2350	1800
	3800	2450	1900
TRIPLEX FREE-LIFT (TREV)	3600	1750	1270
	3800	1817	1337
	4200	1950	1470
	4350	200	1520
	4800	2150	1670
5400	2350	1870	

* i model h1 + 110mm when support legs in upper position; S model h1 - 30 mm

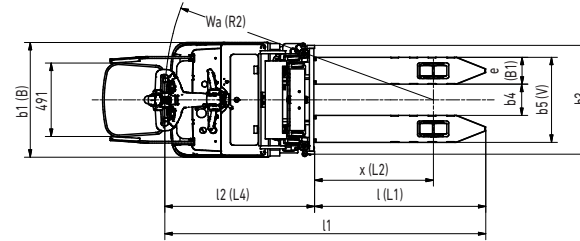
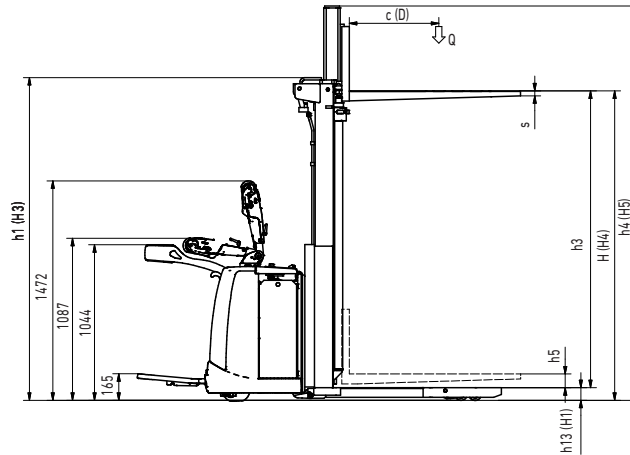

SBV16P(S)

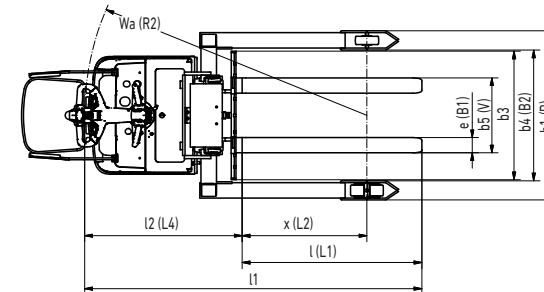
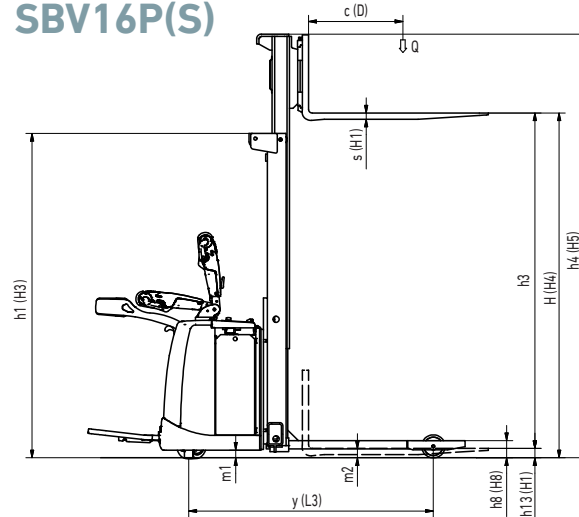

STANDARD EQUIPMENT & OPTIONS

- = Standard
- = Option

	SBV12P	SBV12P(I)	SBV16P	SBV16P(I)	SBV16P(S)
GENERAL					
Micro-computer incl. Hour meter and battery indicator with cut out (ATC T4)	●	●	●	●	●
PIN code log in 100 codes	●	●	●	●	●
Foldable platform	●	●	●	●	●
Foldable sidebars	●	●	●	●	●
Short tiller arm with display and keypad	●	●	●	●	●
Chill store design, down to 1°C, with rust protected axles	●	●	●	●	●
Speed regulated lift motor	●	●	●	●	●
Proportional valve for lowering, controlled by rocker switch on tiller head	●	●	●	●	●
Polyurethan wheels	●	●	●	●	●
Single load wheel polyurtehan	●	●	-	-	●
Tandem load wheels polyurethan	●	●	●	●	●
Battery rollers	●	●	●	●	●
Li-ion batteries	●	●	●	●	●
ENVIRONMENT					
Cold store design, 0C° to -35C°	●	●	●	●	●
DRIVE AND LIFT CONTROLS					
Heavy duty tiller Head - with key switch entry	●	●	●	●	●
Tiller arm - Adjustable in lenght	●	●	●	●	●
Tiller up drive	●	●	●	●	●
WHEEL OPTIONS					
Polyurethan traction and load wheels	●	●	●	●	●
Power friction traction wheel	●	●	●	●	●
Non marking drive wheeel	●	●	●	●	●
Anti static drive wheel	●	●	●	●	●
OTHER OPTIONS					
Driver protected platform rear entry	●	●	●	●	●
Driver protected platform side entry	●	●	●	●	●
Power steering	●	●	●	●	●
Overhead guard	●	●	●	●	●
Load backrest low or high	●	●	●	●	●
Key switch entry	●	●	●	●	●
12V DC Power Socket	●	●	●	●	●
Equipment bar	●	●	●	●	●
Writing desk incl. RAM C holder	●	●	●	●	●
Equipment bar holder RAM system size C	●	●	●	●	●
Equipment bar holder RAM system size C, 2 pcs	●	●	●	●	●
Equipment bar holder RAM size D	●	●	●	●	●
Special RAL colour	●	●	●	●	●

AXIA EM

**SBV12P(i) -16P(I)(S)
Series**

PLATFORM STACKERS

1.2 – 1.6 tonnes



AXIA EM

OPTIONAL LI-ION BATTERY SYSTEMS

MAKE YOUR FORKLIFT (AND ITS FUEL) GO EVEN FURTHER



Tried, tested and proven in the field, lead-acid batteries have been the long-standing top choice for companies employing electric lift trucks. However, with long charging times, demanding maintenance requirements, the need for extra batteries and high risk of operator misuse, it can be a challenge. Fortunately, there's a new battery system on the block: Li-ion from Mitsubishi Forklift Trucks.

Designed to meet your business' demands - including multi-shift (24/7) operations - without the need for spare batteries, our high-performance Li-ion battery system is up to 40 per cent more efficient than lead-acid counterparts. Plus, it's virtually error-proof, thanks to its ultra-low-maintenance design which prevent cell damage.

- **Exceptional, zero-emissions efficiency** 40% more efficient than lead-acid batteries and free from gases.
- **Ultra-low maintenance design** demands just a full charge each week to activate cell balancing, as well as an annual CSV export/update.
- **No space required** With no need for charging areas, there's no cost for set up and you can keep your profitable space just that: profitable..
- **Quick charge capabilities** mean that just 15 minutes is all your battery needs to keep your truck going a few more hours. (It only takes 1 to 2 hours to fully charge a completely discharged battery.)
- **Higher sustained voltage** ensures more consistent lifting and driving performance, which is particularly noticeable towards the end of a shift.
- **TriCOM Technology** delivers exceptionally high system efficiency (up to 97%).
- **Water-free design** With no water in the battery and no need to top up, there's no risk of operators damaging cells.
- **Active protection componentry** This continuously monitors the system, highlighting potential issues, including misuse.
- **Short circuit protection** is offered by system safeguards including: deep-discharge and overcharge protection, individual cell temperature and voltage monitoring.
- **On-the-go performance and monitoring** is possible thanks to the system's integrated monitoring system with easy-to-read display unit, as well as an opportunity charger on board.

Battery capacity, Ah	208	260
Charger capacity, A, 1 – 2,5 hour*	100	200

* Both values possible for 208Ah Li Ion battery, depending on charger.

There is more information on Li-ion on mitforklift.com

For more extensive information please visit our website mitforklift.com

mft2.eu/ion

WHEN RELIABILITY IS EVERYTHING...



AXIA
THE ALL ROUNDER

With a name that reflects its manoeuvrability, AXIA combines award-winning ergonomics with high performance and low maintenance features to deliver a complete warehouse support package.

Efficient, versatile and durable, AXIA is the perfect choice for every workplace.

Like any product bearing the "MITSUBISHI" name our materials handling equipment benefits from the tremendous heritage, huge resources and cutting-edge technology of one of the world's largest corporations – Mitsubishi Heavy Industries Group.

Engineering spacecraft, jet planes, power plants and more, MHI specialises in those technologies where performance, dependability and superiority decide your success or failure...

So when we promise you quality, reliability and value for money, you know it's a guarantee we have the power to deliver.

That's why every model in our award-winning and comprehensive range of lift trucks and warehouse equipment is built to a high specification – to ensure it keeps working for you. Day after day. Year after year. Whatever the job. Whatever the conditions.

YOU'LL NEVER WORK ALONE

As your local authorised dealer, we are here to keep your trucks working – through our extensive experience, our technical excellence and our commitment to customer care.

We are your local experts, backed by efficient channels to the entire organisation of Mitsubishi Forklift Trucks.

No matter where you are, we are close by – with the capability to meet your needs.

Discover how Mitsubishi Forklift Trucks give you more from your local authorised dealer or when you visit our website www.mitforklift.com

Performance specifications may vary depending on standard manufacturing tolerances, vehicle condition, types of tyres, floor or surface conditions, applications or operating environment. Trucks may be shown with non-standard options. Specific performance requirements and locally available configurations should be discussed with your distributor of Mitsubishi forklift trucks. We follow a policy of continual product improvement. For this reason, some materials, options and specifications could change without notice.

mitforklift@mcfe.nl

WESM1990 (10/19) © 2019 MCFE



Mitsubishi Caterpillar Forklift Europe B.V.
Hefbrugweg 77, 1332 AM Almere
The Netherlands
Tel: +31 (0)36 5494 411



mft2.eu/fb



mft2.eu/apps



mft2.eu/youtube



mft2.eu/facebook

