



**Stand-on
Stacker Trucks**
1.2 - 2.0 tonnes



**SBR12N
SBR16N
SBR16NI
SBR20N**

Characteristics						
1.01	Manufacturer (abbreviation)		Mitsubishi	Mitsubishi	Mitsubishi	Mitsubishi
1.02	Manufacturer's model designation		SBR12N	SBR16N	SBR16NI	SBR20N
1.03	Power source: (battery, diesel, LP gas, petrol)		Battery	Battery	Battery	Battery
1.04	Operator type: pedestrian, (operator)-standing, -seated		Stand-on	Stand-on	Stand-on	Stand-on
1.05	Load capacity	Q (kg)	1200	1600	1600	2000
1.06	At load centre	c (mm)	600	600	600	600
1.08	Load wheel axle to fork face (forks lowered)	x (mm)	775	775	760	790
1.09	Wheelbase	y (mm)	1440	1440	1460	1595
Weight						
2.01	Truck weight with nominal load & battery	kg	2775*	3175*	3255*	4415*
2.02	Axle loadings with nominal load & battery, drive/load side	kg	1255/1520*	1295/1880*	1395/1920*	1750/2485*
2.03	Axle loadings without load & with battery, drive/load side	kg	1130/445*	1130/445*	1170/485*	1540/695*
3.01	Tyres: P=Polyurethan, PT=Power Thane, Vul=Vulkollan, drive/load side		Vul/Vul	Vul/Vul	Vul/Vul	Vul/Vul
3.02	Tyre dimensions, front		250x100	250x100	250x100	250x100
3.03	Tyre dimensions, rear		85x75	85x75	85x75	85x90
3.04	Castor wheel dimensions (diameter x width)		150x50	150x50	150x50	150x50
3.05	Number of wheels, front/rear (x=driven)		1x + 2/4	1x + 2/4	1x + 2/4	1x + 2/4
3.06	Track width (centre of tyres), load side	b10 (mm)	385	385	385	375
3.07	Track width (centre of tyres), drive side	b11 (mm)	595	595	595	595
Dimensions						
4.02	Height with mast lowered (see tables)	h1 (mm)	2385*	2385*	2500*	2710*
4.03	Free lift (see tables)	h2 (mm)	1815*	1815*	1815*	2060*
4.04	Lift height (see tables)	h3 (mm)	5400*	5315*	5400*	6300*
4.05	Overall height with mast raised	h4 (mm)	5940*	5940*	6055*	7130*
4.06	Initial lift	h5 (mm)	-	-	115	-
4.07	Height to top of overhead guard	h6 (mm)	2300	2300	2300	2300
4.08	Seat height or platform height	h7 (mm)	235	235	235	235
4.15	Fork height, fully lowered	h13 (mm)	90	90	92	90
4.19	Overall length	l1 (mm)	2000	2000	2050	2160
4.20	Length to fork face (includes fork thickness)	l2 (mm)	850	850	900	1010
4.21	Overall width	b1/b2 (mm)	890/1440**	890/1440**	880/1440**	890/1510**
4.22	Fork dimensions (thickness, width, length)	s / e / l (mm)	65/165/1150	65/165/1150	65/185/1150	65/195/1150
4.25	Outside width over forks (minimum/maximum)	b5 (mm)	550 - 685	550 - 685	570 - 685	570 - 685
4.32	Ground clearance at centre of wheelbase, with load (forks lowered)	m2 (mm)	20	20	20	20
4.33/a	Working aisle width (Ast) with 1000 x 1200 mm pallets, load crosswise	Ast (mm)	2506	2506	2546	2651
4.33/b	Working aisle width (Ast3) with 1000 x 1200 mm pallets, load crosswise	Ast3 (mm)	2090	2090	2140	2215
4.34/a	Working aisle width (Ast) with 800 x 1200 mm pallets, load lengthwise	Ast (mm)	2090	2090	2140	2215
4.34/b	Working aisle width (Ast3) with 800 x 1200 mm pallets, load lengthwise	Ast3 (mm)	2449	2449	2495	2582
4.35	Turning circle radius	Wa (mm)	1665	1665	1700	1820
Performance						
5.01	Travel speed, with/without load	km/h	7.0/8.0	7.0/8.0	7.0/8.0	6.5/7.5
5.02	Lifting speed, with/without load	m/s	0.17/0.31	0.13/0.31	0.13/0.31	0.11/0.31
5.03	Lowering speed, with/without load	m/s	0.5/0.35	0.5/0.35	0.5/0.35	0.5/0.4
5.07	Gradeability, with/without load	%	7/10	7/10	7/10	6/10
5.10	Service brakes (mechanical/hydraulic/electric/pneumatic)		Electric	Electric	Electric	Electric
Electric motors						
6.01	Drive motor capacity (60 min. short duty)	kW	2.2	2.2	2.2	2.2
6.02	Lift motor output at 15% duty factor	kW	5.5	5.5	5.5	5.5
6.04	Battery voltage/capacity at 5-hour discharge	V / Ah	24/375	24/375	24/375	24/575 - 625
6.05	Battery weight	kg	305	305	305	435 - 465
Miscellaneous						
8.01	Type of drive control		Stepless	Stepless	Stepless	Stepless
8.04	Noise level, mean value at operator's ear	dB(A)	68	68	68	62

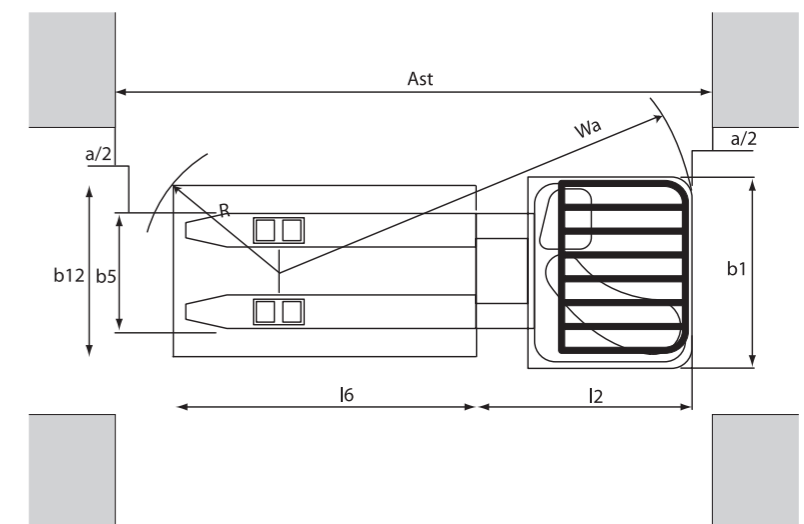
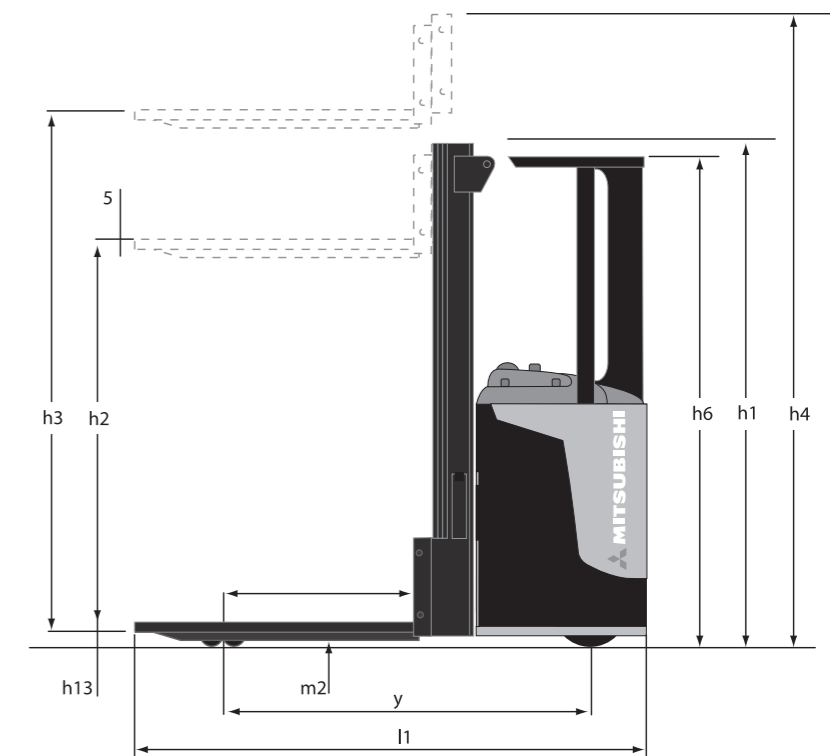

$Ast = Wa + R + a$
 Ast = Working aisle width
 Wa = Turning radius
 a = Safety clearance = 2 x 100 mm
 $R = \sqrt{(l6 - x)^2 + (b12 / 2)^2}$



Clear-view mast and diagonal standing position improve visibility and comfort.



Residual capacity at higher lifts can be increased using side stabilisers (standard on triplex mast).



Armrest reduces driver fatigue.

* With TREV 5400 mm mast on 1200 and 1600 Kg models, 6300 mm mast on 2000 Kg model

** without / with stabilisers extended

Mast Performance and Capacity

SBR12N	Lift height (mm)	Lowered mast height (mm)	Raised mast height (mm)	Free lift (mm)
Simplex	1500	1950	1950	1500
Duplex	2500	1835	3000	200
	2900	2035	3400	200
	3300	2235	3800	200
	3450	2310	3950	200
	3600	2385	4100	200
Duplex with free lift	4300	2735	4800	200
	2500	1835	3000	1365
	2900	2035	3400	1565
	3300	2235	3800	1765
	3450	2310	3950	1840
Triplex	3600	2385	4100	1915
	4300	2735	4800	2265
	5400	2385	5940	-
Triplex with free lift	5900	2555	6440	-
	6500	2755	7040	-
Triplex with free lift	5400	2385	5940	1900
	5900	2555	6440	2070
	6500	2755	7040	2270

SBR16NI	Lift height (mm)	Lowered mast height (mm)	Raised mast height (mm)	Free lift (mm)
Simplex	1500	2065	2065	1500
Duplex	2500	1950	3115	200
	2900	2150	3515	200
	3300	2350	3915	200
	3450	2425	4065	200
	3600	2500	4215	200
Duplex with free lift	4300	2850	4915	200
	2500	1950	3115	200
	2900	2150	3515	200
	3300	2350	3915	200
	3450	2425	4065	200
Triplex	3600	2500	4215	200
	4300	2850	4915	200
	5400	2500	6055	-
Triplex with free lift	5900	2670	6555	-
	6500	2870	7155	-
Triplex with free lift	5400	2500	6055	1900
	5900	2670	6555	2070
	6500	2870	7155	2270

SBR16N	Lift height (mm)	Lowered mast height (mm)	Raised mast height (mm)	Free lift (mm)
Simplex	1500	1950	1950	1500
Duplex	2500	1835	3000	200
	2900	2035	3400	200
	3300	2235	3800	200
	3450	2310	3950	200
	3600	2385	4100	200
Duplex with free lift	4300	2735	4800	200
	2500	1835	3000	1365
	2900	2035	3400	1565
	3300	2235	3800	1765
	3450	2310	3950	1840
Triplex	3600	2385	4100	1915
	4300	2735	4800	2265
	5400	2385	5940	-
Triplex with free lift	5900	2555	6440	-
	6500	2755	7040	-
Triplex with free lift	5400	2385	5940	1900
	5900	2555	6440	2070
	6500	2755	7040	2270

SBR20N	Lift height (mm)	Lowered mast height (mm)	Raised mast height (mm)	Free lift (mm)
Triplex vision	4800	2210	5630	1650
	5400	2410	6230	1850
	5700	2510	6530	1950
	5900	2577	6730	2017
	6300	2710	7130	2150



WESM0964 (10/07)
© 2007 MCFE
Printed in The Netherlands

mitforklift@mcf.nl
www.mitforklift.com

NOTE: Performance specifications may vary depending on standard manufacturing tolerances, vehicle condition, types of tyres, floor or surface conditions, applications or operating environment. Trucks may be shown with non-standard options. Specific performance requirements and locally available configurations should be discussed with your distributor of Mitsubishi Forklift Trucks. Mitsubishi follows a policy of continual product improvement. For this reason, some materials, options and specifications could change without notice.

For duties which involve horizontal movement over large distances, as well as stacking, a Mitsubishi stand-on stacker is ideal. Importantly, these trucks are very compact and can work in narrower aisles than a reach truck.

A choice of three load capacities is available: 1.2, 1.6 and 2.0 tonne. The first two models will lift to a height of 6500 mm and the 2.0 tonne model to 6300 mm. Using the optional side stabilisers, residual capacity at higher lifts is increased.

Productivity is optimised by fast travel and lifting speeds, advanced electronic technology and ergonomic design. The operator enjoys a spacious compartment, quick on-off access, a comfortable standing position, good visibility and highly efficient fly-by-wire steering.

Main features

- *AC drive motor and controller technology for powerful, flexible performance, fully programmable to match the needs of each operator and application perfectly.*
- *Side stabilisers increase residual capacities at higher lifts (standard on triplex mast).*
- *Diagonal standing position improves visibility and operator comfort.*
- *Fly-by-wire steering and compact dimensions allow efficient manoeuvring in very small spaces.*
- *Tapered fork tips ensure smooth, accurate pallet entry.*
- *Regenerative braking conserves energy, for extended shift life, and reduces brake wear.*
- *Built-in diagnostics and easy service access to all components minimises downtime and maximises productivity.*

Options

In addition to the impressive list of standard features, a number of options are available. They include:

- *Initial lift*
- *Single, dual and triple masts*
- *Working lights*
- *Cold storage modification (class II, >-25°C)*

when **reliability** is **everything**

Developed for outstanding performance and genuine value for money, the awardwinning* range of Mitsubishi forklift trucks and warehouse equipment is built to a higher specification to maximize productivity and ensure utter reliability... whatever the application.

It's what you'd expect from one of the world's largest corporations whose companies are at the leading edge of technologies where performance, quality and dependability can never be compromised.

It means that, from a single safe source, we can meet 98% of all handling requirements, supplied to you via a range of competitive finance options including outright purchase, rental or leasing. So your local dealer can advise you on precisely the right product for your application... and your budget.

Moreover, because we understand how much you depend on your Mitsubishi forklift truck, we deliver the highest levels of customer support.

Through a network of carefully selected dealerships, we provide quality maintenance and customer care programmes including a choice of warranties that give complete peace of mind. Every dealership holds extensive stocks of manufacturer-approved parts, backed by a central store that holds literally millions of items constantly in stock and achieves a first-pick fulfilled rate of 97%. So your truck can be fixed first time, virtually every time.

** Mitsubishi Forklift Trucks has won **four** separate Fork Lift Truck Association Annual Awards for Excellence covering the areas of **Ergonomics**, the **Environment** and **Innovation**.*

