

PRELIMINARY  
SPECIFICATIONS

MOVE THE WORLD FORWARD  MITSUBISHI  
HEAVY  
INDUSTRIES  
GROUP

**GRENDIA** EX

# DIESEL AND LPG COUNTERBALANCE TRUCKS

4.0 – 5.5 tonnes

**MAXIMISE YOUR PRODUCTIVITY...  
WITHOUT COMPROMISING ON  
EFFICIENCY**

Tough, reliable and built to work as hard as you do, the class-leading GRENDiA EX promises reliable, class-leading performance - whatever the challenges.

## SPECIFICATIONS

FD40NB	FG40N
FD45NB	FG45N
FD50CNB	FG50CN
FD50NB	FG50N
FD55NB	FG55N



**WHEN  
RELIABILITY IS  
EVERYTHING...**

 **MITSUBISHI  
FORKLIFT TRUCKS**

# GRENDIA EX

## FD / FG40-55(C)N(B) Series

### DIESEL AND LPG COUNTERBALANCE TRUCKS

4.0 – 5.5 tonnes

**Tried and tested in the toughest applications, this no-nonsense design builds on the successes of its predecessors - delivering optimal performance.**

GRENDIA EX's sophisticated Euro 3B compliant engines, coupled with its long-life design, keeps GRENDIA's running costs and maintenance demands low - for maximum efficiency and productivity.

Green inside and out, GRENDIA EX keeps noise and exhaust emissions to a minimum, while delivering improved overall economy.

#### FRAME AND BODY

- **Stylish, purposeful design** reflects this machine's power to work productively, non-stop, whatever the conditions.
- **Robust construction** provides high stability, rigidity and protection, with no exposed wires or hoses.

#### MAST AND FORK ASSEMBLY

- **Strong, high-visibility mast** allows handling of heavy loads in tough environments with total confidence.
- **Wide range of high-quality masts and attachments** deliver precise compatibility and an ideal configuration for each application.

#### DRIVE

- **Turbocharged diesel engine** delivers the power of a 5.0L engine, with the economy of a 3.4L engine, while meeting Euro Stage IIIB standards.

- **Maintenance-free diesel particulate filter** efficiently burns particulate matter while the truck is in operation - avoiding costly downtime.
- **Advanced LPG engine with 3-way catalytic converter** delivers precise, controlled performance and market-leading fuel economy with very low emissions.
- **Fully floating powertrain** with two-speed forward and one-speed reverse transmission maximises gradeability and travel speed, minimises noise and vibration, and uses maintenance-free gears instead of belts to lower running costs.
- **Adjustable transmission shift** timing increases versatility, for optimum performance in a wide variety of applications.
- **Large diameter drive axle shafts** are extremely durable and require little maintenance.

#### STEERING SYSTEM

- **Fully hydrostatic steering system** - together with compact design - ensures effortless, precise and responsive manoeuvring - even in tight spaces.
- **Angle-sensitive steering system** provides quick turning at low speeds and precision control at higher speeds.

#### BRAKES

- **Powerful drum brake system** gives excellent control with little effort and is easy to maintain.

- **Electronically controlled parking brake** allows safe, effective immobilisation of the truck with minimum effort - and without restricting knee and leg movement.

#### HYDRAULICS

- **Powerful hydraulic system** is specifically designed to minimise noise in the operator's environment.

#### ELECTRICAL AND CONTROL SYSTEMS

- **Integrated Presence System 2 (IPS2)** pioneered by Mitsubishi Forklift Trucks prevents all movement of the truck and its mast if the operator is not seated.
- **Operator identification** system can be activated - if owner wishes - to prevent unauthorised use of the truck.
- **Onboard diagnostics and detailed fault diagnosis** via laptop connection alerts operators and service engineers to problems, speeds up servicing and prevents damage.



There is more information on GRENDIA on [mitforklift.com](http://mitforklift.com)

For more extensive information please visit our website [mitforklift.com](http://mitforklift.com)



[mft2.eu/grendiaexd](http://mft2.eu/grendiaexd)

# GRENDIA EX

## FD / FG40-55(C)N(B) Series

### DIESEL AND LPG COUNTERBALANCE TRUCKS

4.0 – 5.5 tonnes



#### OPERATOR COMPARTMENT AND CONTROLS

- **Market-leading ErgoCentric design** results in easy on-off access, a unique, adjustable steering column with position memory, user-friendly controls, a practical layout and great all-round visibility – for maximum precision and productivity.
- **Full-suspension seat** with hip support keeps driver comfortable through the longest of shifts.
- **Hydraulic control levers** are easy to reach and easy to use.
- **Optional fingertip hydraulic controls** with integrated, fully adjustable, high-comfort armrest (an award-winning concept) allows effortless precision.
- **Automotive-style pedals** with optimum pedal angle are easy to use and give good control without leg strain.
- **Low noise level at operator's ear** and low vibration from powertrain increases comfort and reduces fatigue.

- **Clear and comprehensive instrument panel** with LCD display keeps operator and manager fully informed of, for example, speed, time, engine hours, service intervals and faults – to optimise productivity, truck life and safety.
- **PlusCab panel cabin** offering outstanding visibility through laminates glass, and all-round protection from weather elements.

#### OTHER FEATURES

- **Long service interval** and long life of components reduces downtime and associated costs.
- **RapidAccess features** give unequalled ease of entry to all areas for checks and maintenance.
- **Optimal air filter placement** minimises replacement - saving time and money.
- **Belly Seal** protects against damaging dust and debris - preventing the 'cyclone effect' where dust and dirt is drawn into the engine and recirculated into the working environment.

#### FLEXCONTROL INTELLIGENT TRUCK PROTECTION:



- combined with oil-cooled wet disc brakes in an option package for high-intensity applications
- delivers dynamic performance with minimum wear of transmission components and tyres

#### INTEGRATED PRESENCE SYSTEM 2 (IPS2) PROVIDES:



- a hydraulic and travel interlock system that prevents all movement of the truck and its mast if the driver is not seated
- a seat belt warning light
- an automatic parking brake with alarm



There is more information on GRENDIA on [mitforklift.com](http://mitforklift.com)

For more extensive information please visit our website [mitforklift.com](http://mitforklift.com)



[mft2.eu/grendiaexg](http://mft2.eu/grendiaexg)

# VDI - PERFORMANCE & DIMENSIONS

CHARACTERISTICS			Mitsubishi Forklift Trucks	Mitsubishi Forklift Trucks	Mitsubishi Forklift Trucks	Mitsubishi Forklift Trucks	Mitsubishi Forklift Trucks
1.1	Manufacturer		FD40NB	FD45NB	FD50CNB	FD50NB	FD55NB
1.2	Manufacturer's model designation		Diesel	Diesel	Diesel	Diesel	Diesel
1.3	Power source		Seated	Seated	Seated	Seated	Seated
1.4	Operator type		4000	4500	5000	5000	5500
1.5	Load capacity	Q kg	500	500	500	600	600
1.6	Load centre distance	c mm	577	577	582	602	602
1.8	Load distance, axle to fork face	x mm	1850	2000	2000	2150	2150
1.9	Wheelbase	y mm					
WEIGHT							
2.1	Truck weight, without load / including battery (simple x mast, lowest lift height)	kg	5920	6330	6850	7300	7640
2.2	Axle loading with maximum load, front / rear (simple x mast, lowest lift height)	kg	8960 / 960	9710 / 1130	10600 / 1250	11020 / 1280	11740 / 1400
2.3	Axle loading without load, front / rear (simple x mast, lowest lift height)	kg	2630 / 3290	2780 / 3550	2900 / 3950	3220 / 4080	3170 / 4470
WHEELS, DRIVE TRAIN							
3.1	Tyres: V=solid, L=pneumatic, SE=solid pneumatic - front / rear		L / L	L / L	L / L	L / L	SE / SE
3.2	Tyre dimensions, front		8.25 - 15 - 14PR	300 - 15 - 18PR	300 - 15 - 18PR	300 - 15 - 18PR	300 - 15 / 8.00
3.3	Tyre dimensions, rear		7.00 - 12 - 14PR	7.00 - 12 - 14PR	7.00 - 12 - 14PR	7.00 - 12 - 14PR	7.00 - 12 / 5.00
3.5	Number of wheels, front / rear (x=driven)		2 x / 2	2 x / 2	2 x / 2	2 x / 2	2 x / 2
3.6	Track width (centre of tyres), front	b10 mm	1175	1175	1175	1175	1175
3.7	Track width (centre of tyres), rear	b11 mm	1180	1180	1180	1180	1180
DIMENSIONS							
4.1	Mast tilt, forwards / backwards		6 / 12	6 / 12	6 / 12	6 / 12	6 / 12
4.2	Height with mast lowered (see tables)	h1 mm	2320	2320	2400	2400	2400
4.3	Free lift (see tables)		150	150	150	160	160
4.4	Lift height (see tables)	h3 mm	3300	3300	3300	3300	3300
4.5	Overall height with mast raised	h4 mm	3920	3920	4000	4000	4000
4.7	Height to top of overhead guard		2296	2296	2296	2296	2296
4.8	Seat height	h7 mm	1082	1082	1082	1082	1082
4.12	Tow coupling height	h10 mm	395	395	395	395	395
4.19	Overall length	l1 mm	4220	4350	4390	4530	4580
4.20	Length to fork face (includes fork thickness)	l2 mm	3000	3130	3170	3310	3360
4.21	Overall width	b1/b2 mm	1415 / 1965	1460 / 1965	1460 / 1965	1460 / 1965	1460 / 1965
4.22	Fork dimensions (thickness, width, length)	s / e / l mm	50 / 150 / 1220	50 / 150 / 1220	50 / 150 / 1220	60 / 150 / 1220	60 / 150 / 1220
4.23	Fork carriage to DIN 15173 A / B / no		3A	3A	3A	4A	4A
4.24	Fork carriage width	b3 mm	1190	1190	1190	1190	1190
4.31	Ground clearance under mast, with load	m1 mm	150	150	150	150	150
4.32	Ground clearance at centre of wheelbase, with load (forks lowered)	m2 mm	227	227	227	227	227
4.33	Working aisle width with 1000 x 1200 mm pallets, crosswise	Ast mm	4357	4507	4542	4692	4742
4.34a	Working aisle width with 800 x 1200 mm pallets, crosswise	Ast mm	4157	4307	4342	4492	4542
4.34b	Working aisle width with 800 x 1200 mm pallets, lengthwise	Ast mm	4557	4707	4742	4892	4942
4.35	Turning circle radius	Wa mm	2580	2730	2760	2890	2940
4.36	Minimum distance between centres of rotation	b13 mm	836	903	903	971	971
PERFORMANCE							
5.1	Travel speed, with / without load	km/h	19.5 / 20.5	19.5 / 20.5	19.5 / 20.5	19.0 / 20.0	19.0 / 20.0
5.2	Lifting speed, with / without load	m/s	0.55 / 0.61	0.55 / 0.61	0.47 / 0.53	0.47 / 0.53	0.47 / 0.53
5.3	Lowering speed, with / without load	m/s	0.50 / 0.50	0.50 / 0.50	0.50 / 0.50	0.50 / 0.50	0.50 / 0.50
5.5	Rated drawbar pull, with / without load	N	27000 / 17400	27000 / 18700	26500 / 19400	26500 / 21800	26000 / 21300
5.6	Maximum drawbar pull, with / without load (5 min short duty)	N	- / -	- / -	- / -	- / -	- / -
5.7	Gradeability, with / without load	%	29 / 26	26 / 27	24 / 26	23 / 27	21 / 25
5.8	Maximum gradeability with / without load	%	- / -	- / -	- / -	- / -	- / -
5.9	Acceleration time (10 metres) with / without load	s	- / -	- / -	- / -	- / -	- / -
5.10	Service brakes (mechanical / hydraulic / electric / pneumatic)		Hydraulic	Hydraulic	Hydraulic	Hydraulic	Hydraulic
IC ENGINE							
7.1	Manufacturer / Type		854F	854F	854F	854F	854F
7.2	Rated output to ISO 1585 (Gross output)	kW	55	55	55	55	55
7.3	Rated speed to DIN 70020	rpm	2200	2200	2200	2200	2200
7.4	Number of cylinders / cubic capacity	cm <sup>3</sup>	4 / 3400	4 / 3400	4 / 3400	4 / 3400	4 / 3400
7.5	Fuel consumption according to VDI 60 1)	l/h/kg/h	5.1 / -	5.3 / -	5.5 / -	5.6 / -	5.9 / -
7.6a	Max torque	Nm	260	260	260	260	260
7.7a	Max torque at engine speed	rpm	1000	1000	1000	1000	1000
MISCELLANEOUS							
8.1	Type of drive control		Powershift 2 / 1	Powershift 2 / 1	Powershift 2 / 1	Powershift 2 / 1	Powershift 2 / 1
10.1	Maximum operating pressure for attachments	bar	191	191	191	191	191
10.2	Oil flow for attachments	l/min	80	80	80	80	80
10.7	Noise level, value at operator's ear (EN 12053)	dB(A)	84	84	84	84	84
10.8	Towing coupling, type DIN 15170		Pin	Pin	Pin	Pin	Pin

**GRENDIA EX**

**DIESEL  
COUNTERBALANCE**

**FD40 - 55(C)NB**

4.0 – 5.5 tonnes



# VDI - PERFORMANCE & DIMENSIONS

CHARACTERISTICS			Mitsubishi Forklift Trucks	Mitsubishi Forklift Trucks	Mitsubishi Forklift Trucks	Mitsubishi Forklift Trucks	Mitsubishi Forklift Trucks
1.1	Manufacturer		FG40NB	FG45NB	FG50CNB	FG50NB	FG55NB
1.2	Manufacturer's model designation		LPG	LPG	LPG	LPG	LPG
1.3	Power source		Seated	Seated	Seated	Seated	Seated
1.4	Operator type		4000	4500	5000	5000	5500
1.5	Load capacity	Q kg	500	500	500	600	600
1.6	Load centre distance	c mm	577	577	582	602	602
1.8	Load distance, axle to fork face	x mm	1850	2000	2000	2150	2150
1.9	Wheelbase	y mm					
WEIGHT							
2.1	Truck weight, without load / including battery (simple x mast, lowest lift height)	kg	5860	6270	6780	7240	7570
2.2	Axle loading with maximum load, front / rear (simple x mast, lowest lift height)	kg	8940 / 920	9680 / 1090	10570 / 1210	10990 / 1250	11710 / 1360
2.3	Axle loading without load, front / rear (simple x mast, lowest lift height)	kg	2610 / 3250	2750 / 3520	2870 / 3920	3190 / 4050	3130 / 4440
WHEELS, DRIVE TRAIN							
3.1	Tyres: V=solid, L=pneumatic, SE=solid pneumatic - front / rear		L / L	L / L	L / L	L / L	SE / SE
3.2	Tyre dimensions, front		8.25 - 15 - 14PR	300 - 15 - 18PR	300 - 15 - 18PR	300 - 15 - 18PR	300 - 15 / 8.00
3.3	Tyre dimensions, rear		7.00 - 12 - 14PR	7.00 - 12 - 14PR	7.00 - 12 - 14PR	7.00 - 12 - 14PR	7.00 - 12 / 5.00
3.5	Number of wheels, front / rear (x=driven)		2 x / 2	2 x / 2	2 x / 2	2 x / 2	2 x / 2
3.6	Track width (centre of tyres), front	b10 mm	1175	1175	1175	1175	1175
3.7	Track width (centre of tyres), rear	b11 mm	1180	1180	1180	1180	1180
DIMENSIONS							
4.1	Mast tilt, forwards / backwards		6 / 12	6 / 12	6 / 12	6 / 12	6 / 12
4.2	Height with mast lowered (see tables)	h1 mm	2320	2320	2400	2400	2400
4.3	Free lift (see tables)		150	150	150	160	160
4.4	Lift height (see tables)	h3 mm	3300	3300	3300	3300	3300
4.5	Overall height with mast raised	h4 mm	3920	3920	4000	4000	4000
4.7	Height to top of overhead guard		2296	2296	2296	2296	2296
4.8	Seat height	h7 mm	1082	1082	1082	1082	1082
4.12	Tow coupling height	h10 mm	395	395	395	395	395
4.19	Overall length	l1 mm	4220	4350	4390	4530	4580
4.20	Length to fork face (includes fork thickness)	l2 mm	3000	3130	3170	3310	3360
4.21	Overall width	b1/b2 mm	1415 / 1965	1460 / 1965	1460 / 1965	1460 / 1965	1460 / 1965
4.22	Fork dimensions (thickness, width, length)	s / e / l mm	50 / 150 / 1220	50 / 150 / 1220	50 / 150 / 1220	60 / 150 / 1220	60 / 150 / 1220
4.23	Fork carriage to DIN 15173 A / B / no		3A	3A	3A	4A	4A
4.24	Fork carriage width	b3 mm	1190	1190	1190	1190	1190
4.31	Ground clearance under mast, with load	m1 mm	150	150	150	150	150
4.32	Ground clearance at centre of wheelbase, with load (forks lowered)	m2 mm	227	227	227	227	227
4.33	Working aisle width with 1000 x 1200 mm pallets, crosswise	Ast mm	4357	4507	4542	4692	4742
4.34a	Working aisle width with 800 x 1200 mm pallets, crosswise	Ast mm	4157	4307	4342	4492	4542
4.34b	Working aisle width with 800 x 1200 mm pallets, lengthwise	Ast mm	4557	4707	4742	4892	4942
4.35	Turning circle radius	Wa mm	2580	2730	2760	2890	2940
4.36	Minimum distance between centres of rotation	b13 mm	836	903	903	971	971
PERFORMANCE							
5.1	Travel speed, with / without load	km/h	22.0 / 22.5	22.0 / 22.5	22.0 / 22.5	22.0 / 22.5	21.5 / 22.5
5.2	Lifting speed, with / without load	m/s	0.57 / 0.60	0.57 / 0.60	0.49 / 0.52	0.49 / 0.52	0.49 / 0.52
5.3	Lowering speed, with / without load	m/s	0.50 / 0.50	0.50 / 0.50	0.50 / 0.50	0.50 / 0.50	0.50 / 0.50
5.5	Rated drawbar pull, with / without load	N	28000 / 17200	27500 / 18500	27500 / 19200	27000 / 21600	27000 / 21000
5.6	Maximum drawbar pull, with / without load (5 min short duty)	N	- / -	- / -	- / -	- / -	- / -
5.7	Gradeability, with / without load	%	30 / 26	27 / 26	25 / 25	23 / 26	22 / 25
5.8	Maximum gradeability with / without load	%	- / -	- / -	- / -	- / -	- / -
5.9	Acceleration time (10 metres) with / without load	s	- / -	- / -	- / -	- / -	- / -
5.10	Service brakes (mechanical / hydraulic / electric / pneumatic)		Hydraulic	Hydraulic	Hydraulic	Hydraulic	Hydraulic
IC ENGINE							
7.1	Manufacturer / Type		GCT GK45	GCT GK45	GCT GK45	GCT GK45	GCT GK45
7.2	Rated output to ISO 1585 (Gross output)	kW	72	72	72	72	72
7.3	Rated speed to DIN 70020	rpm	2450	2450	2450	2450	2450
7.4	Number of cylinders / cubic capacity	cm <sup>3</sup>	6 / 4452	6 / 4452	6 / 4452	6 / 4452	6 / 4452
7.5	Fuel consumption according to VDI 60 1)	l/h/kg/h	- / 5.3	- / 5.9	- / 6.2	- / 6.3	- / 7.1
7.6a	Max torque	Nm	288	288	288	288	288
7.7a	Max torque at engine speed	rpm	1600	1600	1600	1600	1600
MISCELLANEOUS							
8.1	Type of drive control		Powershift 2 / 1	Powershift 2 / 1	Powershift 2 / 1	Powershift 2 / 1	Powershift 2 / 1
10.1	Maximum operating pressure for attachments	bar	191	191	191	191	191
10.2	Oil flow for attachments	l/min	80	80	80	80	80
10.7	Noise level, value at operator's ear (EN 12053)	dB(A)	84	84	84	84	84
10.8	Towing coupling, type DIN 15170		Pin	Pin	Pin	Pin	Pin

**GRENDIA EX**

**LPG  
COUNTERBALANCE**

**FD40 - 55(C)N**

4.0 – 5.5 tonnes



# MAST PERFORMANCE AND CAPACITY

**GRENDIA EX**

## FD40-45NB / FG40 - 45N

MAST TYPE	FD40NB / FG40N FD45NB / FG45N					FD40NB/FG40N PNEUMATIC		FD45NB/FG45N PNEUMATIC		FD40NB/FG40N SOLID PNEUMATIC		FD45NB/FG45N SOLID PNEUMATIC	
	h3 mm	h1 mm	h4 mm	h2 / h5 mm	Tilt angle (fwd - back)	Q@ c=500mm kg	Q@ c=600mm kg	Q@ c=500mm kg	Q@ c=600mm kg	Q@ c=500mm kg	Q@ c=600mm kg	Q@ c=500mm kg	Q@ c=600mm kg
SIMPLEX	3000	2170	4130	150	- 6°/12°	4000	3500	4500	4000	4000	3500	4500	4000
	3300	2320	4430	150	- 6°/12°	4000	3500	4500	4000	4000	3500	4500	4000
	3700	2520	4830	150	- 6°/12°	4000	3500	4500	4000	4000	3500	4500	4000
	4000	2700	5130	150	- 6°/12°	4000	3500	4500	4000	4000	3500	4500	4000
	4500	3000	5630	150	- 6°/6°	4000	3500	4500	4000	4000	3500	4500	4000
	5000	3250	6130	150	- 6°/6°	3850	3500	4500	4000	4000	3500	4500	4000
	5500	3500	6630	150	- 6°/6°	3650*	3400*	4300*	4000*	3700	3500	4400	4000
6000	3750	7130	150	- 6°/6°	3500*	3300*	3900*	3900*	3600	3400	4250	3900	
DUPLEX	3000	2170	4130	- 1090	6°/12°	4000	3500	4500	4000	4000	3500	4500	4000
	3300	2320	4430	- 1240	6°/12°	4000	3500	4500	4000	4000	3500	4500	4000
	3700	2520	4830	- 1440	6°/12°	4000	3500	4500	4000	4000	3500	4500	4000
	4100	2700	5190	- 1620	6°/12°	4000	3500	4500	4000	4000	3500	4500	4000
TRIPLEX	3700	1950	4830	- 870	6°/6°	4000	3500	4500	4000	4000	3500	4500	4000
	4000	2050	5130	- 970	6°/6°	4000	3500	4500	4000	4000	3500	4500	4000
	4360	2170	5490	- 1090	6°/6°	4000	3500	4500	4000	4000	3500	4500	4000
	4700	2285	5830	- 1200	6°/6°	3900	3500	4500	4000	4000	3500	4500	4000
	5050	2400	6180	- 1320	6°/6°	3800	3500	4500	4000	3900	3500	4500	4000
	5500	2550	6630	- 1470	6°/6°	3600*	3400*	4200*	4000*	3700	3450	4350	4000
	6000	2750	7130	- 1670	6°/6°	3450*	3250*	4050*	3800*	3550	3300	4200	3900
	6500	2950	7630	- 1870	6°/6°	3000*	3000*	3000*	3000*	3350	3200	4050*	3800*
7000	3150	8130	- 2070	6°/6°	2400*	2400*	2400*	2400*	3300*	3100*	3500*	3500*	

\* Truck equipped with dual tyres. Consult your dealer for the maximum back-tilt allowed, to obtain the capacities specified.

## FD50CNB / FG50CN

MAST TYPE	FD50CNB / FG50CN					FD50CNB/FG50CN PNEUMATIC		FD50CNB/FG50CN SOLID PNEUMATIC	
	h3 mm	h1 mm	h4 mm	h2 / h5 mm	Tilt angle (fwd - back)	Q@ c=500mm kg	Q@ c=600mm kg	Q@ c=500mm kg	Q@ c=600mm kg
SIMPLEX	3000	2250	4130	150	- 6°/12°	5000	4500	5000	4500
	3300	2400	4430	150	- 6°/12°	5000	4500	5000	4500
	3700	2600	4830	150	- 6°/12°	5000	4500	5000	4500
	4000	2850	5130	150	- 6°/12°	5000	4500	5000	4500
	4500	3100	5630	150	- 6°/6°	5000	4500	5000	4500
	5000	3350	6130	150	- 6°/6°	5000	4500	5000	4500
	5500	3600	6630	150	- 6°/6°	4750*	4500*	4750*	4500*
6000	3850	7130	150	- 6°/6°	3900*	3900*	4700	4400	
DUPLEX	3000	2250	4100	- 1170	6°/12°	5000	4500	5000	4500
	3300	2400	4410	- 1320	6°/12°	5000	4500	5000	4500
	4100	2850	5210	- 1770	6°/12°	5000	4500	5000	4500
	3700	2050	4830	- 970	6°/6°	5000	4500	5000	4500
TRIPLEX	4040	2170	5170	- 1090	6°/6°	5000	4500	5000	4500
	4310	2260	5440	- 1180	6°/6°	5000	4500	5000	4500
	4750	2400	5880	- 1320	6°/6°	5000	4500	5000	4500
	5050	2500	6180	- 1420	6°/6°	5000	4500	5000	4500
	5500	2650	6630	- 1570	6°/6°	4700*	4450*	4800	4500
	6000	2850	7130	- 1770	6°/6°	4200*	4200*	4600*	4350
	6500	3050	7630	- 1970	6°/6°	3000*	3000*	4450*	4200*
	7000	3250	8130	- 2170	6°/6°	2400*	2400*	3500*	3500*

- h1 Height with mast lowered
- h2 Standard free lift
- h3 Lift height
- h4 Height with mast raised
- h5 Full free lift
- Q Lifting capacity, rated load
- c Load centre (distance)

- Ast = Working aisle width
- Wa = Turning radius
- a = Safety clearance = 2 x 100 mm
- l6 = Pallet length
- b12 = Pallet width

## FD50CNB / FG50CN

MAST TYPE	FD50NB / FG50N FD55NB / FG55N					FD50NB/ FG50N PNEUMATIC		FD55NB/ FG55N SOLID PNEUMATIC	
	h3 mm	h1 mm	h4 mm	h2 / h5 mm	Tilt angle (fwd - back)	Q@ c=600mm kg	Q@ c=600mm kg	Q@ c=600mm kg	Q@ c=600mm kg
SIMPLEX	3000	2250	4280	150	- 6°/12°	5000	5500	4500	5500
	3300	2400	4580	150	- 6°/12°	5000	5500	4500	5500
	3700	2600	4980	150	- 6°/12°	5000	5500	4500	5500
	4000	2850	5280	150	- 6°/12°	5000	5500	4500	5500
	4500	3100	5780	150	- 6°/6°	5000	5500	4500	5500
	5000	3350	6280	150	- 6°/6°	5000	5500*	4500	5500
	5500	3600	6780	150	- 6°/6°	4900*	(4650)*	4500	5500
6000	3850	7280	150	- 6°/6°	4100*	(3450)*	4400	5350*	
DUPLEX	3000	2250	4250	- 1030	6°/12°	5000	5500	4500	5500
	3300	2400	4560	- 1180	6°/12°	5000	5500	4500	5500
	4100	2850	5360	- 1630	6°/12°	5000	5500	4500	5500
	3700	2050	4980	- 830	6°/6°	5000	5500	4500	5500
TRIPLEX	4040	2170	5320	- 950	6°/6°	5000	5500	4500	5500
	4310	2260	5590	- 1040	6°/6°	5000	5500	4500	5500
	4500	2320	5790	- 1100	6°/6°	5000	5500	4500	5500
	4750	2400	6030	- 1180	6°/6°	5000	5450	4500	5500
	5050	2500	6330	- 1280	6°/6°	5000	5500*	4500	5500
	5500	2650	6780	- 1430	6°/6°	4900*	-	4350	5500
	6000	2850	7280	- 1630	6°/6°	4300*	-	4200*	5300*

\* Truck equipped with dual tyres. Consult your dealer for the maximum back-tilt allowed, to obtain the capacities specified.

### FD/FG40-55(C)N(B) Models Capacities at various load centres

Simplex - h3 = 4000 mm

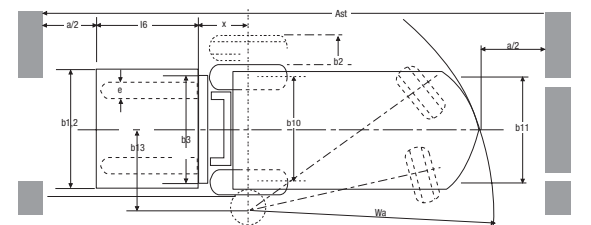
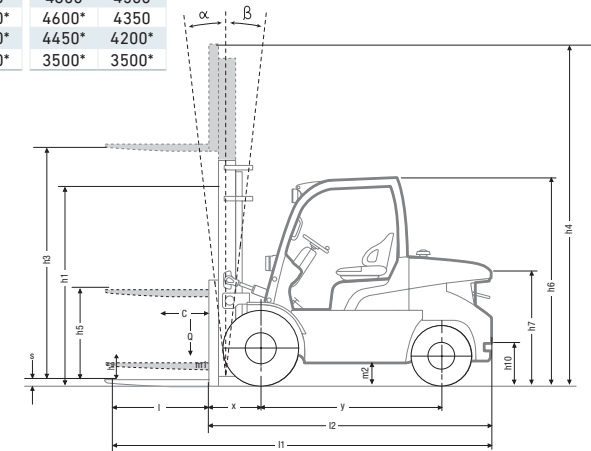
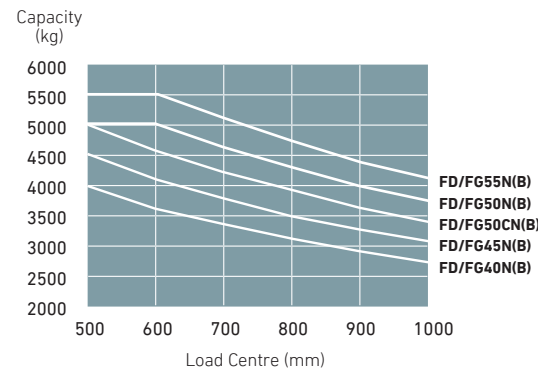

Continuing improvement may lead to changes in these specifications

# STANDARD EQUIPMENT & OPTIONS

● = Standard  
● = Option

	FD40-458NB	FD50CNB	FD50NB	FD55NB	FG40-45N	FG50CN	FG50N	FG55N
<b>DIESEL</b>					<b>LPG</b>			
<b>GENERAL</b>								
Dust proof kit	●	●	●	●	●	●	●	●
Line filter for torque converter	●	●	●	●	●	●	●	●
Universal joint cover powertrain	●	●	●	●	●	●	●	●
LPG bracket removed	●	●	●	●	●	●	●	●
Rear axle under guard	●	●	●	●	●	●	●	●
Tilt cylinder boot kit	●	●	●	●	●	●	●	●
Lifting eyes mounted on counter weight	●	●	●	●	●	●	●	●
Belly plate (under cover)	●	●	●	●	●	●	●	●
Dust proof strainer	●	●	●	●	●	●	●	●
Hydraulic oil cooler	●	●	●	●	●	●	●	●
<b>HYDRAULIC</b>								
3-way control valve MC	●	●	●	●	●	●	●	●
3-way control valve FC	●	●	●	●	●	●	●	●
4-way control valve MC	●	●	●	●	●	●	●	●
4-way control valve FC	●	●	●	●	●	●	●	●
<b>MAST, FORKS AND CARRIAGE</b>								
Loose mast	●	●	●	●	●	●	●	●
Lifting eye for mast	●	●	●	●	●	●	●	●
Uninstalled mast	●	●	●	●	●	●	●	●
Side shifter 1190 mm	●	●	●	●	●	●	●	●
Side shifter 1500 mm* (*Note: Requires Carriage 1500mm)	●	●	●	●	●	●	●	●
Integral side shifter 1190mm	●	●	●	●	●	●	●	●
Fork deletion	●	●	●	●	●	●	●	●
<b>ELECTRIC</b>								
Backup handle with horn button	●	●	●	●	●	●	●	●
Electric diesel control (Diesel)	●	●	●	●	●	●	●	●
Speed control system (LPG)	●	●	●	●	●	●	●	●
Indicator kit	●	●	●	●	●	●	●	●
LED light set	●	●	●	●	●	●	●	●
LED rear work light	●	●	●	●	●	●	●	●
Load weight indicator (for simplex & triplex masts)	●	●	●	●	●	●	●	●
Rotating beacon (orange)	●	●	●	●	●	●	●	●
Strobe light (orange)	●	●	●	●	●	●	●	●
FNR switch on adjustable armrest* (*Standard on FC models)	●	●	●	●	●	●	●	●

## GRENDIA EX FD / FG40-55(C)N(B) Series DIESEL AND LPG COUNTERBALANCE TRUCKS

4.0 – 5.5 tonnes



Convenient handbrake button

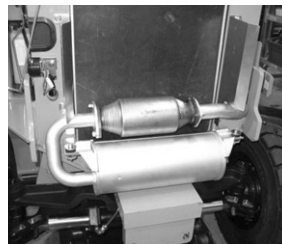

Advanced LPG technology



User-friendly hydraulic features



Fingertip hydraulic controls (optional)

# STANDARD EQUIPMENT & OPTIONS

● = Standard  
● = Option

	FD40-458NB	FD50CNB	FD50NB	FD55NB	FG40-45N	FG50CN	FG50N	FG55N
<b>OHG AND CABIN</b>								
	DIESEL				LPG			
Grammer MSG 65 Vinyl seat	●	●	●	●	●	●	●	●
Grammer MSG 65 Cloth seat	●	●	●	●	●	●	●	●
Armrest LH side (for FC models)	●	●	●	●	●	●	●	●
Armrest LH side (for MC models)	●	●	●	●	●	●	●	●
Armrest RH side (for FC models)	●	●	●	●	●	●	●	●
Armrest RH side (for MC models)	●	●	●	●	●	●	●	●
Rear view mirrors	●	●	●	●	●	●	●	●
Convenience tray (*Only for MC models)	●	●	●	●	●	●	●	●
Panel cabin	●	●	●	●	●	●	●	●
<b>TYRES</b>								
Solid pneumatic tyres	●	●	●	●	●	●	●	●
Pneumatic tyres	●	●	●	●	●	●	●	●
Solid pneumatic dual drive tyres	●	●	●	●	●	●	●	●
Pneumatic dual drive tyres	●	●	●	●	●	●	●	●
<b>ENVIRONMENT</b>								
Single element air cleaner	●	●	●	●	●	●	●	●
Double element air cleaner	●	●	●	●	●	●	●	●
Elevated exhaust	●	●	●	●	●	●	●	●

Contact your dealer for additional standard and optional equipment.

## GRENDIA<sup>EX</sup> FD / FG40-55(C)N(B) Series DIESEL AND LPG COUNTERBALANCE TRUCKS

4.0 – 5.5 tonnes



Front LED working lights



Stylish, robust design



Auto-style pedals



PlusCab panel cabin



Pneumatic tyres



# WHEN RELIABILITY IS EVERYTHING...



**GRENDIA**  
THE GREEN DIAMOND

The green colour of our trucks is a sign of our commitment to protecting the environment.

The diamond shapes in our logo are a reminder that – like a diamond – a Mitsubishi forklift truck guarantees quality, reliability and a sound investment.

Like any product bearing the "MITSUBISHI" name our materials handling equipment benefits from the tremendous heritage, huge resources and cutting-edge technology of one of the world's largest corporations – Mitsubishi Heavy Industries Group.

Engineering spacecraft, jet planes, power plants and more, MHI specialises in those technologies where performance, dependability and superiority decide your success or failure...

So when we promise you quality, reliability and value for money, you know it's a guarantee we have the power to deliver.

That's why every model in our award-winning and comprehensive range of lift trucks and warehouse equipment is built to a high specification – to ensure it keeps working for you. Day after day. Year after year. Whatever the job. Whatever the conditions.

## YOU'LL NEVER WORK ALONE

As your local authorised dealer, we are here to keep your trucks working – through our extensive experience, our technical excellence and our commitment to customer care.

We are your local experts, backed by efficient channels to the entire organisation of Mitsubishi Forklift Trucks.

No matter where you are, we are close by – with the capability to meet your needs.

Discover how Mitsubishi Forklift Trucks give you more from your local authorised dealer or when you visit our website [www.mitforklift.com](http://www.mitforklift.com)

Performance specifications may vary depending on standard manufacturing tolerances, vehicle condition, types of tyres, floor or surface conditions, applications or operating environment. Trucks may be shown with non-standard options. Specific performance requirements and locally available configurations should be discussed with your distributor of Mitsubishi forklift trucks. We follow a policy of continual product improvement. For this reason, some materials, options and specifications could change without notice.

[mitforklift@mcfe.nl](mailto:mitforklift@mcfe.nl)

CESM1982 (10/19) © 2019 MCFE



Mitsubishi Caterpillar Forklift Europe B.V.  
Hefbrugweg 77, 1332 AM Almere  
The Netherlands  
Tel: +31 (0)36 5494 411



[mft2.eu/fb](http://mft2.eu/fb)



[mft2.eu/apps](http://mft2.eu/apps)



[mft2.eu/youtube](http://mft2.eu/youtube)



[mft2.eu/facebook](http://mft2.eu/facebook)

