

# TREXiA EX

Diesel Counterbalance  
6 Wheel Pneumatic Tyres • 10.0 – 16.0 tonnes

FD100N  
FD120N  
FD135N  
FD150N  
FD160N

## Engineered to perform... built to last

**Demanding applications can take a toll on your forklift trucks... and your budgets. That's why TREXiA EX 10.0 to 16.0 tonne diesel counterbalance trucks have been specially developed to deliver outstanding lifting performance and non-stop reliability.**

The secret to TREXiA EX's powerful performance is its twin-turbocharged, Stage IIIB compliant four-cylinder Perkins engine. It offers exceptional efficiency during acceleration – without reducing the truck's top speed of up to 32 km/h.

A forklift, however, is only as productive as its operator, so TREXiA EX is highly intuitive to drive – giving operators the precise, predictable and effortless performance they need to maximise their potential – whatever the environment.

In short, it's everything you'd expect from a Mitsubishi forklift... and then some.

### Frame and body

- **Optimal counterweight design** delivers ideal weight positioning, allowing for a shorter turning radius with maximum residual capacity.
- **Full-floating drive axle** increases load capacity for heavy-duty applications.
- **Robust steer axle** is all-in-one, ensuring exceptional strength and rigidity.
- **Heavy-duty steel frame** optimised by finite element modelling offers superior durability.
- **Low centre of gravity** and rugged design result in higher residual capacity.
- **Low counterweight design** provides optimum visibility during reverse operations.
- **Fully enclosed wheel arches** protect vital components from dust – minimising the risk of premature failure and reducing noise.

### Mast and fork assembly

- **High visibility mast** utilises narrow mast channels and slim lift cylinders to provide exceptional operator visibility.
- **Six-roller mast with side rollers** – as standard – ensures load stability, while keeping fork lift tips and load in full view.
- **Easy-to-reach lubrication points** allow for easy maintenance.



## Diesel Counterbalance 6 Wheel Pneumatic Tyres • 10.0 – 16.0 tonnes

Characteristics						
1.1	Manufacturer (abbreviation)		Mitsubishi	Mitsubishi	Mitsubishi	
1.2	Manufacturer's model designation		FD100N	FD120N	FD135N	
1.3	Power source: (battery, diesel, LP gas, petrol)		Diesel	Diesel	Diesel	
1.4	Operator type: pedestrian, (operator)-standing, -seated		Seated	Seated	Seated	
1.5	Load capacity	Q (kg)	10000	12000	13500	
1.6	Load center distance	c (mm)	600	600	600	
1.8	Load distance, axle to fork face	x (mm)	770	780	800	
1.9	Wheelbase	y (mm)	2800	2800	2800	
Weight						
2.1	Truck weight, without load / including battery (simplex mast, lowest lift height)	kg	14610	15860	17480	
2.2	Axle loading with maximum load, front/rear (simplex mast, lowest lift height)	kg	22150 / 2460	25130 / 2730	27940 / 3040	
2.3	Axle loading without load, front/rear (simplex mast, lowest lift height)	kg	7260 / 7350	7230 / 8630	7700 / 9780	
Wheels, Drive Train						
3.1	Tyres: V=solid, L=pneumatic, SE=solid pneumatic - front/rear		L / L	L / L	L / L	
3.2	Tyre dimensions, front		10.00 × 20 - 14 PR	10.00 × 20 - 16 PR	12.00 × 20 - 18 PR	
3.3	Tyre dimensions, rear		10.00 × 20 - 14 PR	10.00 × 20 - 16 PR	12.00 × 20 - 18 PR	
3.5	Number of wheels, front/rear (x=driven)		4x / 2	4x / 2	4x / 2	
3.6	Track width (center of tyres), front	b10 (mm)	1905	1905	1905	
3.7	Track width (center of tyres), rear	b11 (mm)	1965	1965	1925	
Dimensions						
4.1	Mast tilt, forwards/backwards	$\alpha/\beta$ °	15 / 12	15 / 12	15 / 12	
4.2	Height with mast lowered (see tables)	h1 (mm)	3087	3087	3332	
4.3	Free lift (see tables)	h2 (mm)	72	72	88	
4.4	Lift height (see tables)	h3 (mm)	3072	3072	3088	
4.5	Overall height with mast raised	h4 (mm)	4486	4486	4927	
4.7	Height to top of overhead guard	h6 (mm)	3015	3020	3060	
4.8	Seat height	h7 (mm)	1915	1915	1960	
4.12	Tow coupling height	h10 (mm)	695	695	740	
4.19	Overall length	l1 (mm)	5530	5610	5755	
4.20	Length to fork face (includes fork thickness)	l2 (mm)	4310	4390	4535	
4.21	Overall width	b1 (mm)	2515	2515	2605	
4.22	Fork dimensions (thickness, width, length)	s / e / l (mm)	72 × 180 × 1220	79 × 180 × 1220	88 × 180 × 1220	
4.23	Fork carriage to DIN 15 173 A/B/no		no	no	no	
4.24	Fork carriage width	b3 (mm)	2010	2010	2260	
4.31	Ground clearance under mast, with load	m1 (mm)	260	260	305	
4.32	Ground clearance at center of wheelbase, with load (forks lowered)	m2 (mm)	310	310	355	
4.33	Working aisle width with 1000 x1200 mm pallets, crosswise	Ast (mm)	5970	6040	6160	
4.34a	Working aisle width with 800 x1200 mm pallets, lengthwise	Ast (mm)	6170	6240	6360	
4.35	Turning circle radius	Wa (mm)	4000	4060	4160	
4.36	Minimum distance between centers of rotation	b13 (mm)	1565	1565	1565	
Performance						
5.1	Travel speed, with/without load	(mm)	26.5 / 31.0	25.0 / 31.0	25.5 / 32.0	
5.2	Lifting speed, with/without load	m/s	0.41 / 0.44	0.41 / 0.44	0.34 / 0.37	
5.3	Lowering speed, with/without load	m/s	0.45 / 0.47	0.45 / 0.47	0.45 / 0.48	
5.5	Rated drawbar pull, with/without load	N	107000 / 34000	121000 / 33000	11000 / 35000	
5.7	Gradeability, with/without load	%	42.1 / 21.7	42.2 / 19.7	38.9 / 18.8	
5.10	Service brakes (mechanical/hydraulic/electric/pneumatic)		Pneumatic / Hydraulic	Pneumatic / Hydraulic	Pneumatic / Hydraulic	
IC Engine						
7.1	Manufacturer / Type		Perkins 1204E	Perkins 1204E	Perkins 1204E	
7.2	Rated / Nominal output to ISO 1585**	kW	129	129	129	
7.3	Rated speed to DIN 70 020	rpm	2200	2200	2200	
7.4	Number of cylinders / cubic capacity	cm <sup>3</sup>	4 / 4400	4 / 4400	4 / 4400	
Miscellaneous						
8.1	Type of drive control		Powershift / 3	Powershift / 3	Powershift / 3	
8.2	Maximum operating pressure for attachments	bar	206	206	206	
8.3	Oil flow for attachments	l/min	-	-	-	
8.4	Noise level, value at operator's ear (EN 12053)	dB(A)	85	85	85	
8.5	Towing coupling design / DIN type, ref.		Pin	Pin	Pin	

# FD100N/FD120N Model

## Mast Performance and Capacity

		FD100N, FD120N				FD100N		FD120N
Mast type		h3	h1	h4	h2/h5	Tilt	Q @	Q @
		mm	mm	mm	mm	deg	c = 600mm kg	c = 600mm kg
Simplex	V120A30	3072	3087	4486	72	15°F/12°B	10000	12000
	V120A35	3572	3337	4986	72	15°F/12°B	10000	12000
	V120A37	3772	3437	5186	72	15°F/12°B	10000	12000
	V120A40	4072	3587	5486	72	15°F/12°B	10000	12000
	V120A45	4572	3837	5986	72	15°F/12°B	10000	12000
	V120A50	5072	4087	6486	72	15°F/12°B	10000	12000
	V120A55	5572	4337	6986	72	15°F/12°B	10000	12000
	V120A60	6072	4637	7486	72	6°F/6°B	9800	11800

# FD135N/FD150N Model

## Mast Performance and Capacity

		FD135N, FD150N				FD135N		FD150N
Mast type		h3	h1	h4	h2/h5	Tilt	Q @	Q @
		mm	mm	mm	mm	deg	c = 600mm kg	c = 600mm kg
Simplex	4V135A30	3088	3332	4927	88	15°F/12°B	13500	15000
	4V135A35	3588	3632	5427	88	15°F/12°B	13500	15000
	4V135A37	3788	3732	5627	88	15°F/12°B	13500	15000
	4V135A40	4088	3882	5927	88	15°F/12°B	13500	15000
	4V135A45	4588	4132	6427	88	15°F/12°B	13500	15000
	4V135A50	5088	4382	6927	88	15°F/12°B	13500	15000
	4V135A55	5588	4682	7427	88	15°F/12°B	13500	15000
	4V135A60	6088	4932	7927	88	6°F/6°B	13300	14600

# FD160N Model

## Mast Performance and Capacity

		FD160N				FD160N	
Mast type		h3	h1	h4	h2/h5	Tilt	Q @
		mm	mm	mm	mm	deg	c = 600mm kg
Simplex	V160A30	3092	3530	4927	92	15°F/12°B	16000
	V160A35	3592	3780	5427	92	15°F/12°B	16000
	V160A37	3792	3880	5627	92	15°F/12°B	16000
	V160A40	4092	4030	5927	92	15°F/12°B	16000
	V160A45	4592	4280	6427	92	15°F/12°B	16000
	V160A50	5092	4530	6927	92	15°F/12°B	16000
	V160A55	5592	4830	7427	92	15°F/12°B	16000
	V160A60	6092	5080	7927	92	6°F/6°B	15800

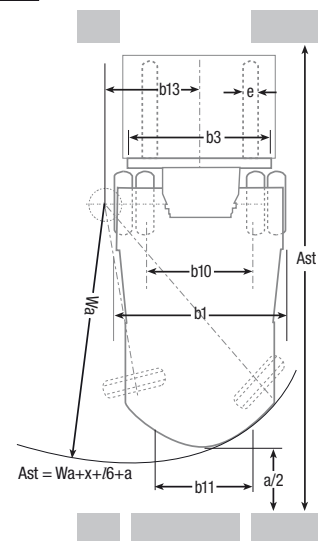
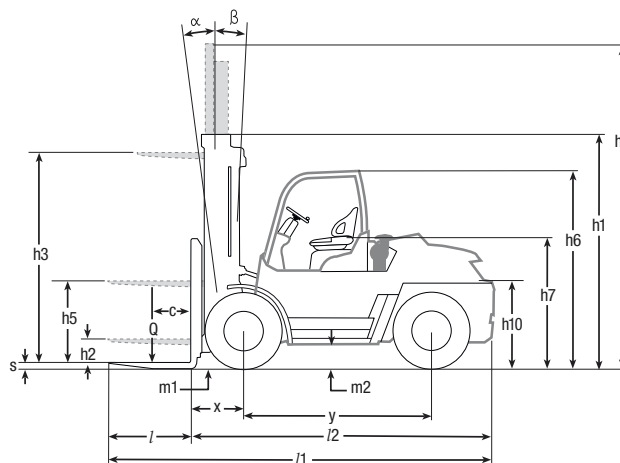

- Ast = Working aisle width
- Wa = Turning radius
- a = Safety clearance = 2 × 100 mm
- l6 = Pallet length (800 or 1000 mm)
- b12 = Pallet width (1200 mm)



	Mitsubishi FD150N	Mitsubishi FD160N
	Diesel	Diesel
	Seated	Seated
	15000	16000
	600	600
	805	820
	3100	3300
	18050	18940
	30055 / 2995	31895 / 3045
	8260 / 9790	9025 / 9915

	L / L	L / L
	12.00 × 20 - 18 PR	12.00 × 20 - 18 PR
	12.00 × 20 - 18 PR	12.00 × 20 - 18 PR
	4x / 2	4x / 2
	1905	1905
	1925	1890

	15 / 12	15 / 12
	3332	3530
	88	92
	3088	3092
	4927	4927
	3060	3060
	1960	1960
	735	735
	6060	6275
	4840	5055
	2605	2635
	88 × 180 × 1220	92 × 180 × 1220
	no	no
	2280	2280
	300	300
	355	355
	6555	6835
	6755	7035
	4550	4550
	1815	2000

	25.0 / 32.0	24.5 / 31.5
	0.34 / 0.37	0.32 / 0.34
	0.45 / 0.48	0.41 / 0.44
	110000 / 38000	109000 / 42000
	36.2 / 20.0	33.4 / 21.1
	Pneumatic / Hydraulic	Pneumatic / Hydraulic

	Perkins 1204E	Perkins 1204E
	129	129
	2200	2200
	4 / 4400	4 / 4400

	Powershift / 3	Powershift / 3
	206	206
	-	-
	85	85
	Pin	Pin



Premium LED/LCD information panel



Spacious operator compartment



Easy access step and grab handle

## Drive

- **Powerful four-cylinder Perkins engine** delivers 13% more fuel efficiency, compared with previous models.
- **Twin turbochargers** offer rapid response for maximise operator performance.
- **Low-maintenance diesel particulate filter** with passive regeneration features through-flow ceramic filter for efficient burning of particulate matter.

## Hydraulics

- **Large, easy-to-reach levers** give operators precise control of hydraulics – with minimum effort.
- **Intuitive fingertip controls** available as an option offers the ultimate in driver ergonomics and, if needed, can even be operated using heavy, protective gloves.

## Electrical and control systems

- **EngineProtect as standard** continuously monitors and regulates RPM levels – reducing power output when vital fluids are low to reduce the risk of damage.

- **Integrated Presence System (IPS)** provides parking brake alarm, seat belt, warning light and hydraulic and interlock system for added safety.

## Operator compartment and controls

- **Small-diameter steering wheel**, with full hydrostatic steering assistance, ensures precise and rapid steering response – with very little effort.
- **Premium information display** keeps operators aware of issues affecting performance – from fuel levels to fluid temperatures – encouraging good maintenance.
- **Wide steps with grab handles** offer easy on/off access to the spacious operator's compartment – reducing operator fatigue and risk of slips, trips and falls.
- **Generous leg room** with tiltable steering column and adjustable full-suspension seat ensures a relaxed driving position for all operators.

## Other features

- **RapidAccess features** include quick release floor and side panels – no tools required – for faster daily inspections.
- **Low-noise design** features rubber-mounted components, fully insulated steel engine hood, helical gears and enclosed wheel arches for maximum operator comfort.
- **500-hour service interval** and long component life reduces downtimes and associated costs.

## Options

- **Intuitive fingertip controls**
- **Cabin options, with heater and air conditioner**
- **Engine shut down system**
- **Fork positioners and sidesifters**



when  
**reliability**  
is **everything**

Like any product bearing the Mitsubishi name, our materials handling equipment benefits from the huge resources and cutting-edge technology of one of the world's largest corporations. So when we promise you **quality, reliability** and **value for money**, you know it's a guarantee we have the power to deliver.

Every model in our comprehensive, award-winning range of forklift trucks and warehouse equipment is built to a high specification and is designed to keep on working for you... day after day... year after year... whatever the job... whatever the conditions.

To ensure your truck stays in constant productive action, we have a network of local dealers – hand-picked for their commitment to customer care... and backed up by the Mitsubishi Forklift Trucks organisation. No matter where you are, we have a dealer close by – ready and willing to meet your needs.

That friendly local service covers everything from identifying the perfect model and configuration for your application to providing competitive, flexible finance and maintenance packages, unbeatable warranties, long and short term hire, and highly responsive field service and repairs... as well as the industry's quickest and most reliable parts supply.

Only Mitsubishi can give you this combination of global engineering excellence and outstanding local support... only Mitsubishi offers you such a quality product at such an affordable price... and only Mitsubishi places reliability as high as you do in its priorities. Contact your local dealer now and see what Mitsubishi can do for you.

You can find your nearest dealer at [www.mitforklift.com](http://www.mitforklift.com)

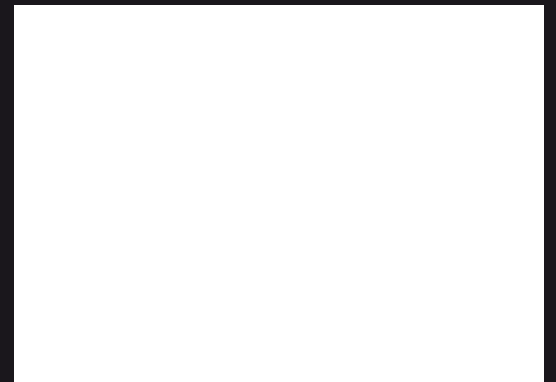

CESM1655 (03/15)  
© 2015 MCFE  
Printed in The Netherlands

[mitforklift@mcf.nl](mailto:mitforklift@mcf.nl) [www.mitforklift.com](http://www.mitforklift.com)

NOTE: Performance specifications may vary depending on standard manufacturing tolerances, vehicle condition, types of tyres, floor or surface conditions, applications or operating environment. Trucks may be shown with non-standard options. Specific performance requirements and locally available configurations should be discussed with your distributor of Mitsubishi forklift trucks. Mitsubishi follows a policy of continual product improvement. For this reason, some materials, options and specifications could change without notice.